



# **Ditec DAB105**

## Swing doors

(translation of the original instructions)

IP2159EN  
**Technical Manual**

# Contents

	Subject	Page
1.	General safety precautions	3
2.	General safety precautions for the user	4
	Declaration of incorporation of partly completed machinery	5
3.	Technical specifications	6
4.	Standard installation	7
5.	Dimensions	8
6.	Main components	9
7.	Installation	10
7.1	Preliminary checks	10
7.2	General information	10
7.3	Installation examples	10
7.4	Removing the cover	11
8.	Automation with articulated arm DAB805PSA	12
8.1	Set-up	12
8.2	Fixing the automation	13
8.3	Fixing the arm	15
8.4	Assembling the right-hand articulated arm	15
9.	Automation with articulated arm DAB805PSAF	16
9.1	Set-up	16
9.2	Fixing the automation	17
9.3	Fixing the arm	19
10.	Automation with sliding arm DAB805PLA	20
10.1	Set-up	20
10.2	Fixing the automation	21
10.3	Fixing the arm	24
10.4	Fixing the door stop	25
11.	Connecting to the electricity supply	26
12.	Starting up the door	27
13.	Electrical connections	28
13.1	Commands	28
13.2	Outputs and accessories	29
13.3	Adjustments	30
14.	Pre-configured parameters	32
15.	Door requisites for Low Energy use	33
16.	Example of an application with a standard automation	34
17.	ESE extension unit	35
17.1	Commands	35
17.2	Outputs and accessories	37
17.3	Adjustments	37
18.	ESA extension unit	38
18.1	Commands	38
18.2	Outputs and accessories	39
18.3	Adjustments	40
19.	Example of an application with optional extension units	41
20.	Parallel and interlocked automations	42
21.	Electrical start-up	45
22.	Routine maintenance plan	45
23.	Troubleshooting	46
24.	Signs	47

## Key



This symbol indicates instructions or notes regarding safety, to which special attention must be paid.



This symbol indicates useful information for the correct functioning of the product.



This symbol advises you to contact the Technical Service.

# 1. General safety precautions



This installation manual is intended for qualified personnel only.

Installation, electrical connections and adjustments must be performed in accordance with Good Working Methods and in compliance with the present standards. Read the instructions carefully before installing the product.

Incorrect installation could be dangerous.



The packaging materials (plastic, polystyrene, etc.) should not be discarded in the environment or left within reach of children, as they are a potential source of danger. Before installing the product, make sure it is in perfect condition.

Do not install the product in explosive areas and atmospheres: the presence of inflammable gas or fumes represents a serious safety hazard.

Before installing the motorisation device, make all the necessary structural modifications to create safety clearance and to guard or isolate all the crushing, shearing, trapping and general hazardous areas.

Make sure the existing structure is up to standard in terms of strength and stability. The motorisation device manufacturer is not responsible for failure to observe Good Working Methods when building the frames to be motorised, or for any deformations during use.

The safety devices (photocells, safety edges, emergency stops, etc.) must be installed taking into account the applicable laws and directives, Good Working Methods, installation premises, system operating logic and the forces developed by the motorised door.



The safety devices must protect the crushing, shearing, trapping and general hazardous areas of the motorised door. Display the signs required by law to identify hazardous areas.

Each installation must bear a visible indication of the data identifying the motorised door.

When requested, connect the motorised door to an effective earthing system that complies with current safety standards. During installation, maintenance and repair operations, cut off the power supply before opening the cover to access the electrical parts.

The automation protection casing must be removed by qualified personnel only.



The electronic parts must be handled using earthed antistatic conductive arms. The manufacturer of the motorisation declines all responsibility if component parts not compatible with safe and correct operation are fitted.

Only use original spare parts when repairing or replacing products.

The installer must supply all information on the automatic, manual and emergency operation of the motorised door, and must provide the user with the operating instructions.

All the rights concerning this material are the exclusive property of Entrematic Group AB.

Although the contents of this publication have been drawn up with the greatest care, Entrematic Group AB cannot be held responsible in any way for any damage caused by mistakes or omissions in this publication. We reserve the right to make changes without prior notice. Copying, scanning or changing in any way is expressly forbidden unless authorised in writing by Entrematic Group AB.

## General safety precautions for the user

These precautions are an integral and essential part of the product and must be supplied to the user.

Read them carefully since they contain important information on safe installation, use and maintenance.

These instructions must be kept and forwarded to all possible future users of the system.

This product must only be used for the specific purpose for which it was designed.

Any other use is to be considered improper and therefore dangerous. The manufacturer cannot be held responsible for any damage caused by improper, incorrect or unreasonable use.

This product must not be used by people (including children) with reduced physical, sensorial or mental abilities, or lack of experience or knowledge, unless they are given proper surveillance and instructions for operating the device by a person responsible for their safety.

Avoid operating in the proximity of the hinges or moving mechanical parts.

Do not enter within the operating range of the motorised door while it is moving.

Do not block the movement of the motorised door since this may be dangerous.

Do not allow children to play or stay within the operating range of the motorised door.

Keep remote controls and/or any other control devices out of the reach of children in order to avoid possible involuntary activation of the motorised door.

In the event of a product fault or malfunction, turn off the power supply switch. Do not attempt to repair or intervene directly, and contact only qualified personnel.

Failure to comply with the above may cause a dangerous situation.

All cleaning, maintenance or repair work must be carried out by qualified personnel.

To ensure that the system works efficiently and correctly, the manufacturer's indications must be complied with and only qualified personnel must perform routine maintenance of the motorised door.

In particular, regular checks are recommended in order to verify that the safety devices are operating correctly.

All installation, maintenance and repair work must be documented and made available to the user.

 To dispose of electrical and electronic equipment correctly, users must take the product to special "recycling centres" provided by the municipal authorities.

# Declaration of incorporation of partly completed machinery

We:

Entrematic Group AB  
Lodjursgatan 10  
SE-261 44 Landskrona  
Sweden

declare under our responsibility that the following types of equipment:

Ditec DAB105

comply with the following directives:

2004/108/EC      Electromagnetic Compatibility Directive (EMCD)  
2006/42/EC      Machinery Directive (MD) for the following essential health and safety requirements: 1.1.2, 1.1.3, 1.2.1, 1.2.3, 1.2.4, 1.2.6, 1.3.2, 1.3.4, 1.5.1, 1.5.2, 1.5.3, 1.5.8, 1.5.9, 1.5.10, 1.5.11, 1.6.3, 1.7.3, 1.7.4

Technical documentation for safe integration supplied.

Harmonised European standards which have been applied:

EN 60335 -1      EN 61000 -6-2      EN 61000 -6-3      EN ISO 13849 -1      EN 16005

Other standards or technical specifications, which have been applied:

BBR      BVL      EN 60335-2-103

CE type examination or certificate issued by a notified or competent body (for the full address, contact Entrematic Group AB) for the equipment:

SC0250-14

The production process aims to guarantee that the equipment complies with the technical documentation.  
The production process is regularly assessed by an independent body.

The equipment must not be put into service until the final door system installed has been declared compliant with the Machinery Directive 2006/42/EC by the installer.

Person in charge of technical data sheet:

Marco Pietro Zini      E-mail: marco.zini@entrematic.com

Entrematic Group AB  
Lodjursgatan 10  
SE-261 44 Landskrona  
Sweden

Place  
Landskrona

Date  
2015-09-01

Signature  
Marco Pietro Zini



Position  
Entrance Automation President

### 3. Technical specifications

DAB105																						
Power	100-240V~ +10/-15% 50/60 Hz																					
Consumption	max. 75W																					
Power supply for accessories	24V = 400 mA max.																					
Power supply fuse F1-F2	2xT6.3A 250 V																					
Opening time	min. 3s / 0°-80° max. 6s / 0°-80°																					
Closing time	min. 3s / 90°-10° max. 6s / 90°-10°																					
Max. inertia (J / kg <sup>2</sup> )	<div style="display: flex; align-items: flex-start;"> <div style="flex: 1;"> <p>Inertia <math>J = \frac{\text{door weight} \times (\text{door width})^2}{3}</math></p> <p>DAB805PSA: 45kg m<sup>2</sup></p> <p>DAB805PLA: 16kg m<sup>2</sup></p> </div> <div style="flex: 2;"> <table border="1"> <caption>Door Weight vs Door Width Data</caption> <thead> <tr> <th>Door Width [m]</th> <th>DAB805PSA [kg]</th> <th>DAB805PLA [kg]</th> </tr> </thead> <tbody> <tr><td>0.7</td><td>200</td><td>150</td></tr> <tr><td>0.8</td><td>200</td><td>150</td></tr> <tr><td>0.9</td><td>170</td><td>125</td></tr> <tr><td>1.0</td><td>140</td><td>100</td></tr> <tr><td>1.1</td><td>115</td><td>80</td></tr> <tr><td>1.2</td><td>90</td><td>70</td></tr> </tbody> </table> </div> </div>	Door Width [m]	DAB805PSA [kg]	DAB805PLA [kg]	0.7	200	150	0.8	200	150	0.9	170	125	1.0	140	100	1.1	115	80	1.2	90	70
Door Width [m]	DAB805PSA [kg]	DAB805PLA [kg]																				
0.7	200	150																				
0.8	200	150																				
0.9	170	125																				
1.0	140	100																				
1.1	115	80																				
1.2	90	70																				
Type of operation	Motor opening Spring-plus-motor closure																					
Maximum wing weight (see inertia graph)	150 kg DAB805PLA 200 kg DAB805PSA																					
Door wing width	700 ÷ 1200 mm																					
Minimum number of manoeuvres in AVERAGE conditions of use	1,000,000 cycles																					
Temperature	min. -20°C max. +45°C																					
Degree of protection	IP20 (FOR INTERNAL USE ONLY)																					

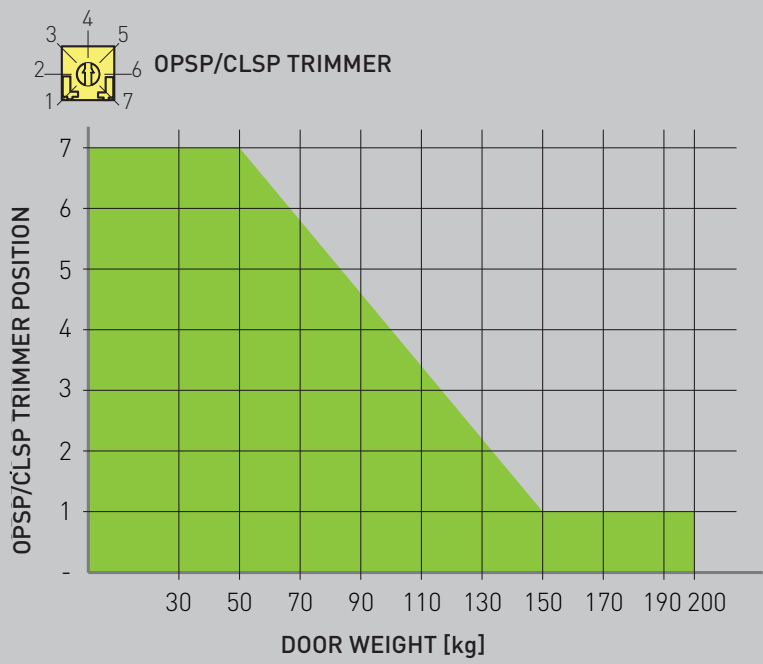

## 4. Standard installation

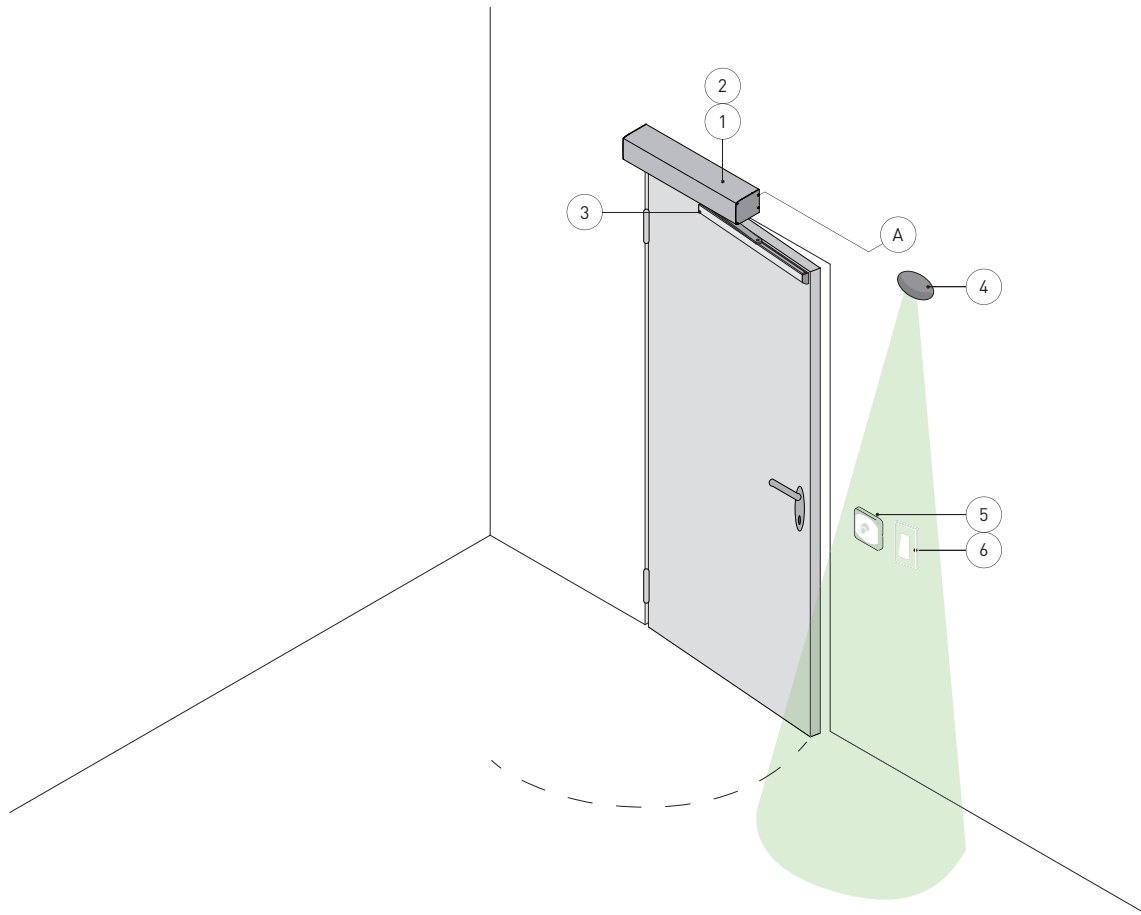

Ref.	Code	Description
1	DAB105	Electro-mechanical actuator
2		Control panel
3	DAB805PSA-PSAF DAB805PLA DAB805PLAT DAB805PLAB	Articulated movement arm Sliding movement arm Movement arm with three levers Sliding movement arm (break-out/anti-panic)
4		Opening sensor
5	COM400MHB COM400MKB	Function selector switch
6		Command button
A		Connect the power supply to a type-approved omnipolar switch, with a contact opening distance of at least 3 mm (not supplied). Connection to the mains must be via an independent channel, separate from the connections to the control and safety devices.

# 5. Dimensions

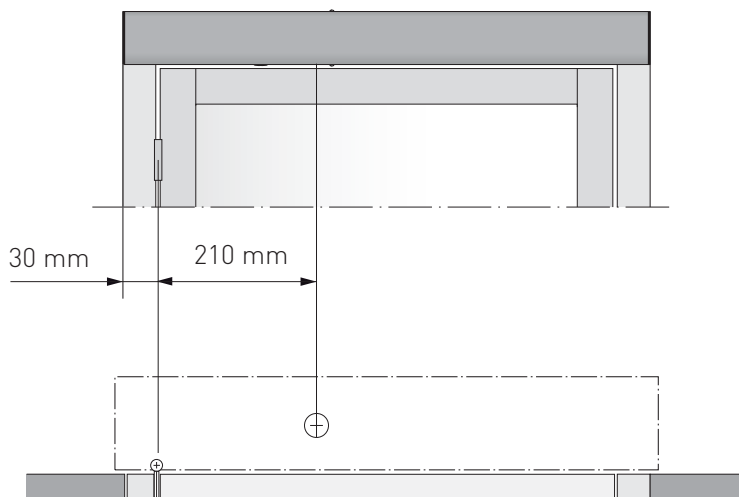
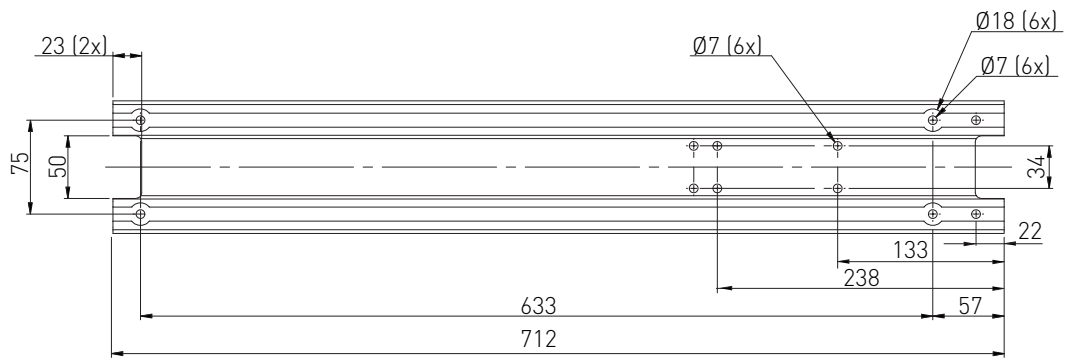
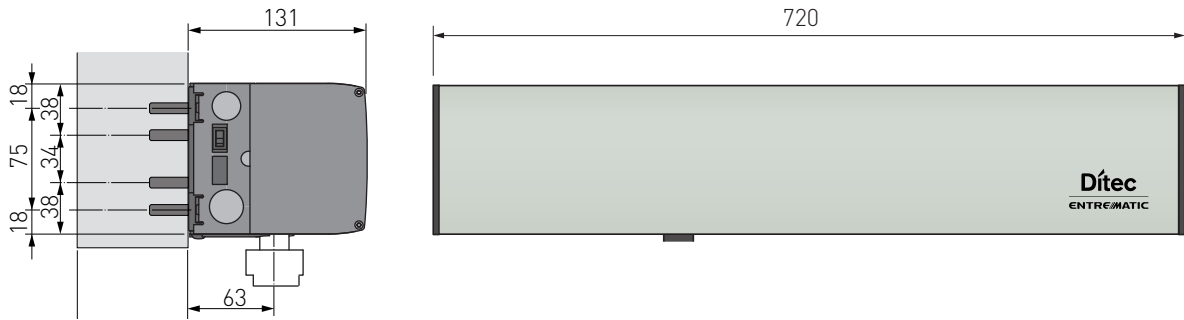

## 6. Main components

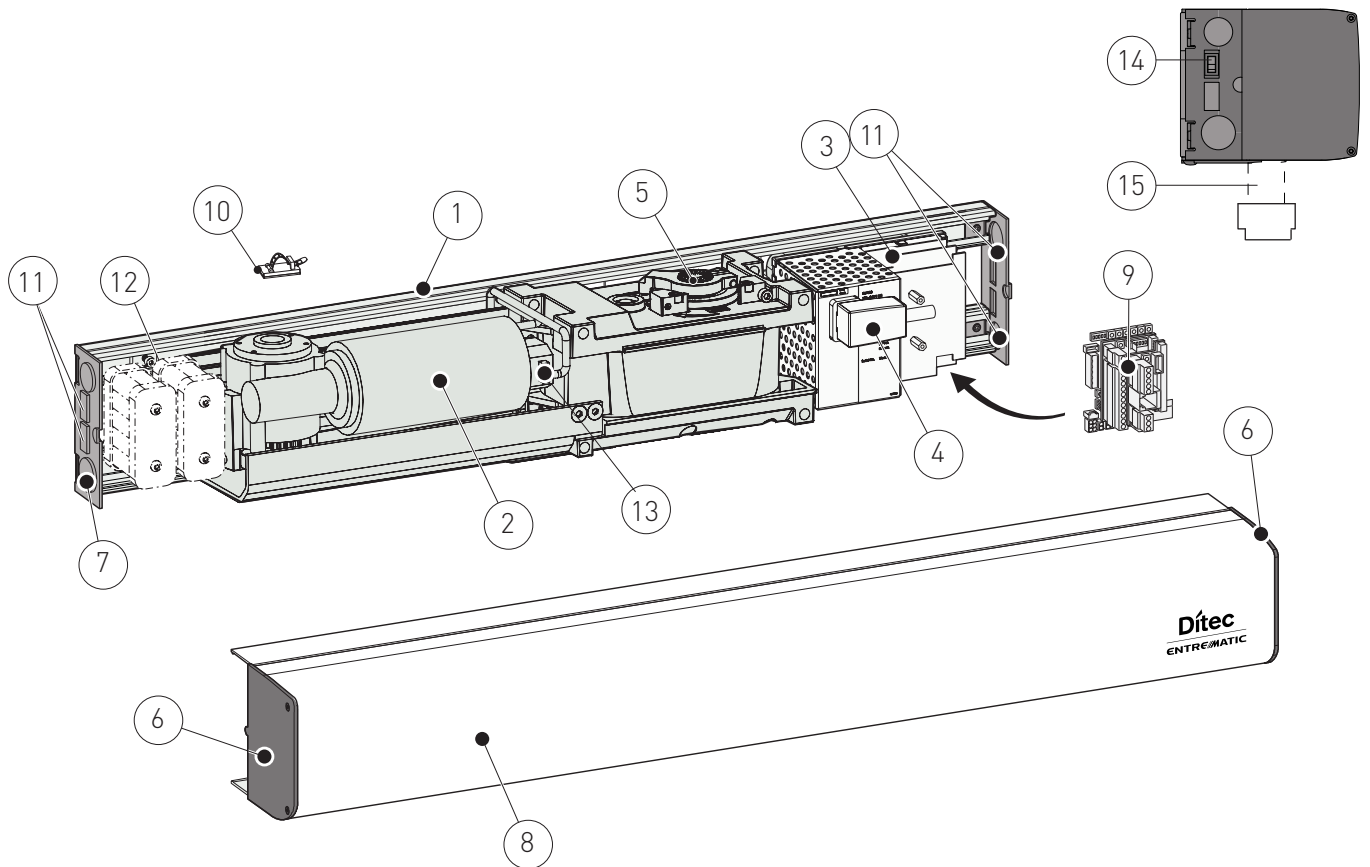

Ref.	Code	Description
1		Base plate
2		Gearmotor
3	<b>DAB105CU</b>	Control panel
4		Power
5		End stop
6		Upper head
7		Lower head
8		Casing
9	<b>DAB905ESE</b> <b>DAB905ESA</b>	Safety and pulse extension card (optional) Extension card for safety functions (optional)
10		Cable fastener
11		Cable transit slits
12	<b>DAB905BAT</b>	Battery kit
13		Encoder
14		ON/OFF/HOLD OPEN switch
15		Arm extension kit
		20mm      50mm      70mm      50mm
	<b>DAB805SE2</b> <b>DAB805SE5</b> <b>DAB805SE7</b>	
	<b>DAB805SE5F</b>	
		<b>DAB805SE2</b> <b>DAB805SE5</b> <b>DAB805SE7</b> <b>DAB805SE5F</b>

## 7. Installation

The given operating and performance features can only be guaranteed with the use of DITEC Entrematic accessories and safety devices. Unless otherwise specified, all measurements are expressed in mm.

### 7.1 Preliminary checks

Check the stability and weight of the door wing. Make sure it moves smoothly, without any friction (reinforce the frame if necessary). Any "door closers" must be removed or completely annulled.

### 7.2 General information

The DAB105 automation for swing doors can use articulated or sliding arms to open the doors.

The door is closed by a spring system, combined with the force of the motor.

The spring is pre-tensioned at 210°.

**i** Do not alter the pre-tensioning of the spring unless it is strictly necessary.

### 7.3 Installation examples

The DAB105 automation for swing doors can be installed on one swing door, on two swing doors, or on two swing doors with a double exit.

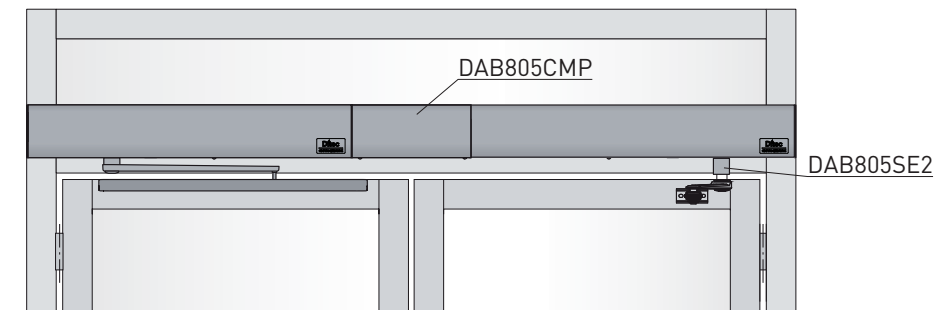
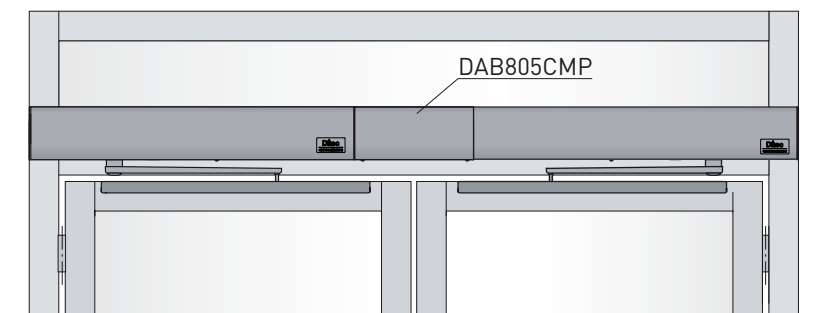
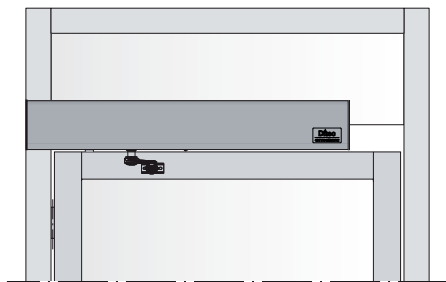



## 8. Automation with articulated arm DAB805PSA

Use the articulated arm for doors that open outwards (as seen from the automation side).

**i** Before fixing the base plate [1], make holes for the cables to pass through.

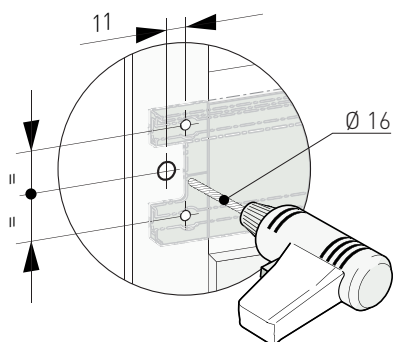

	X
DAB805PSA	30
DAB805PSA DAB805SE2	50
DAB805PSA DAB805SE5	80
DAB805PSA DAB805SE7	100

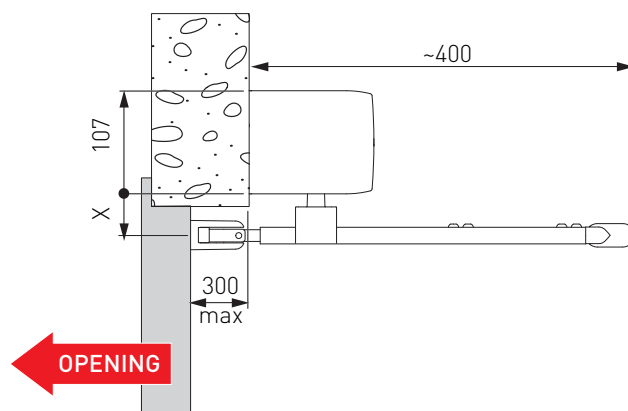

### 8.1 Set-up

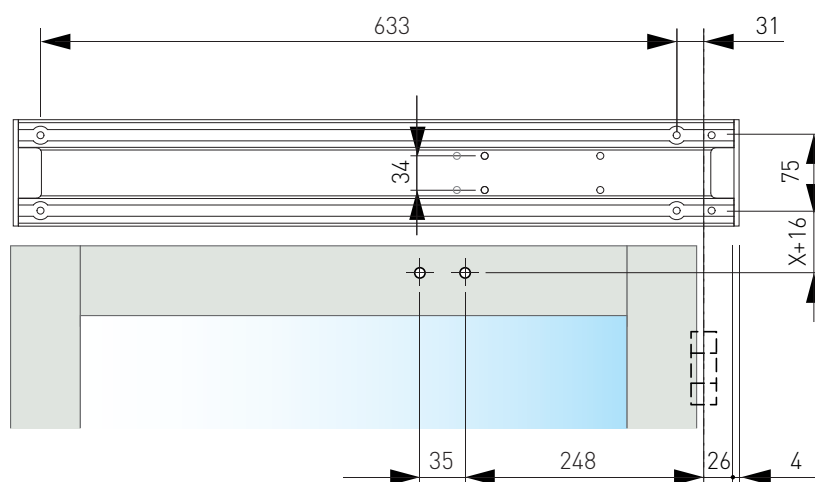
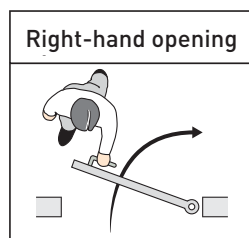
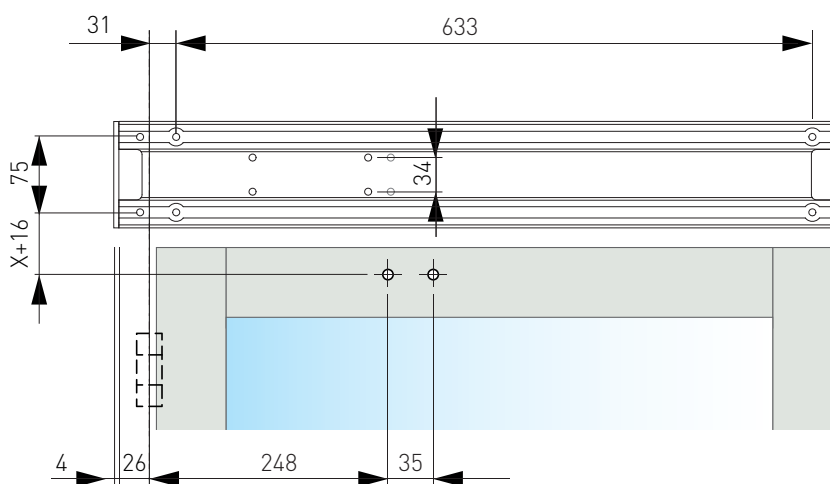
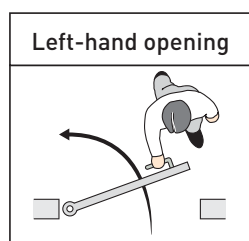

- Prepare the set-up for fixing the automation to the wall, respecting the measurements shown in the figures above (with reference to the hinge axis).
- Drill a hole in the door wing, in line with the fixing for the articulated arm.
- If necessary, use the DAB805SE2/SE5/SE7 extensions to increase the X measurement between the automation and the arm fixing points.

## 8.2 Fixing the automation

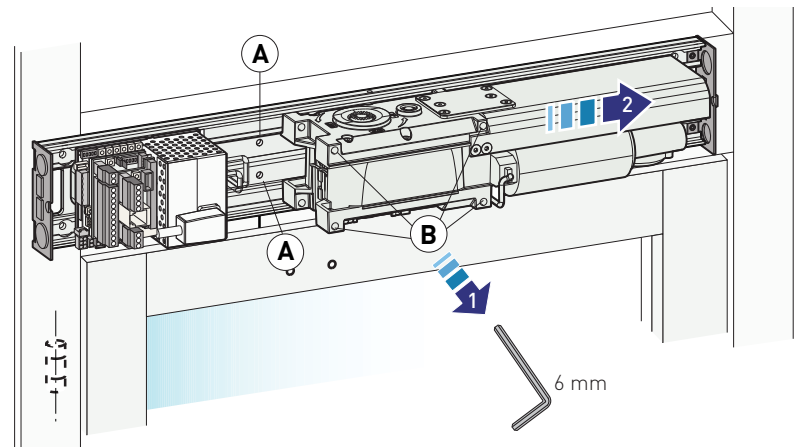
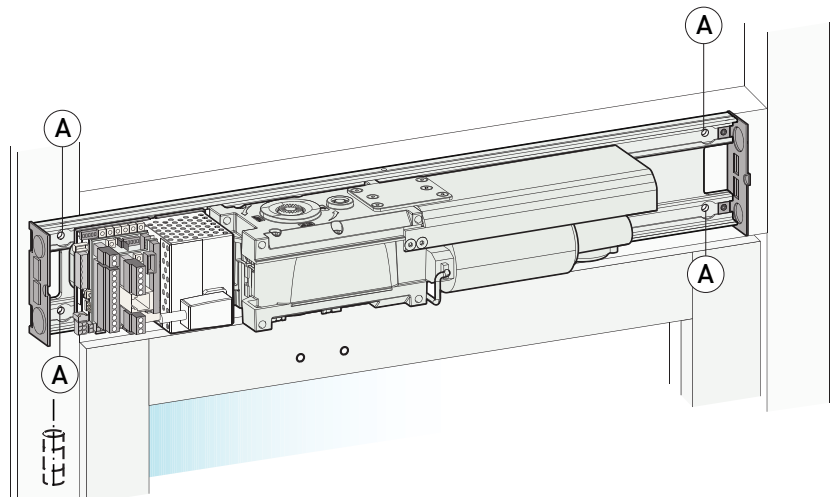
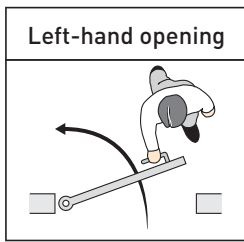

- Fix the automation in place using the screws [A]; tighten them firmly and evenly.
- Move the gearmotor sideways by loosening the 4 screws [B], so the base plate can be fixed in place.
- Fix the base plate with the screws [A].

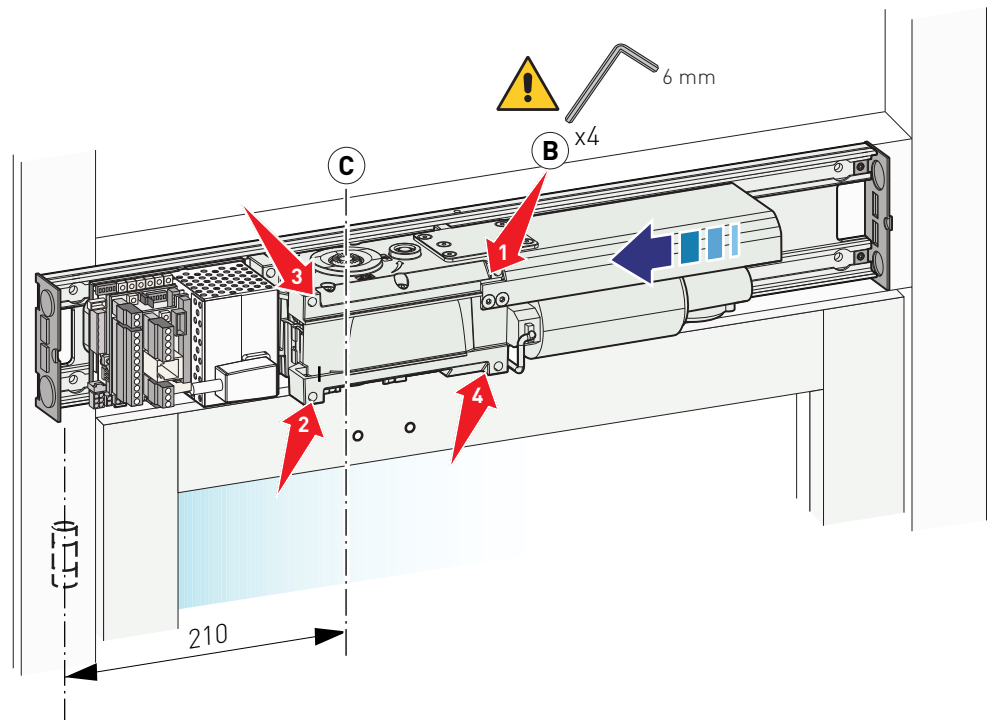

- Return the motor to its original position.
- Fix the motor by tightening the 4 screws [B] supplied, in the sequence shown in the figure.



Respect the measurement between the hinge and the gearmotor shaft output [C], as shown in the figure.

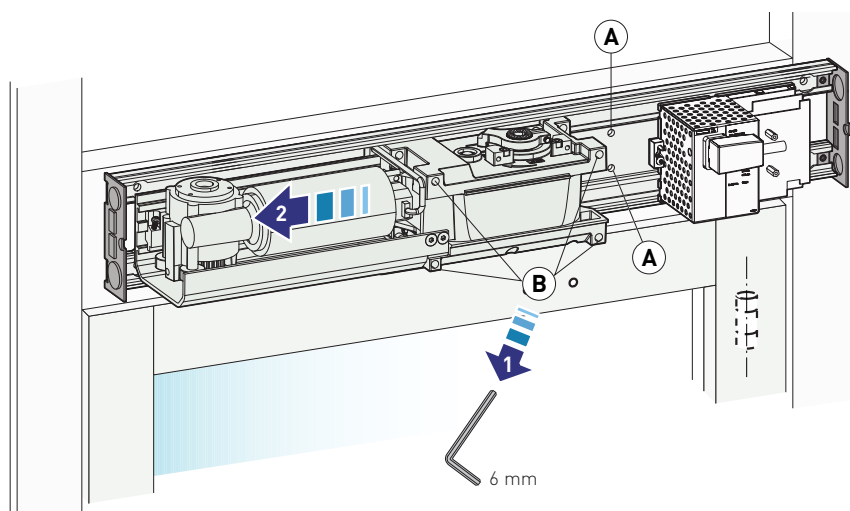
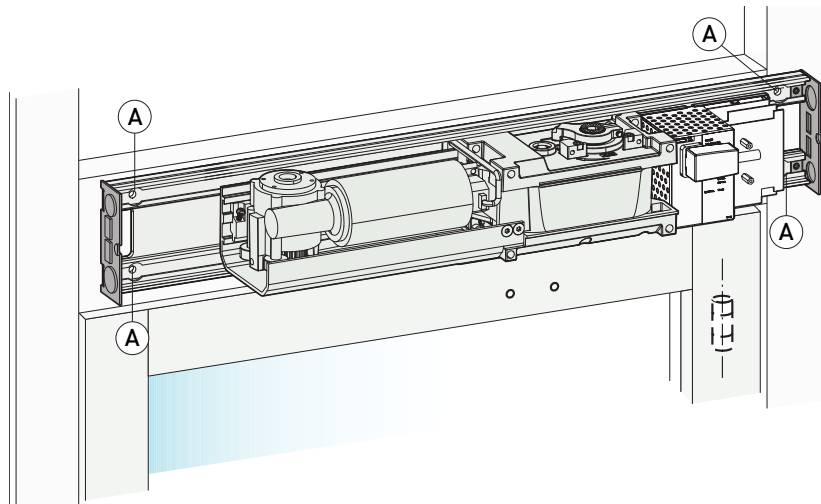
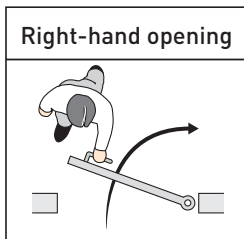

- Fix the automation using the screws [A], tightening them firmly.
- Move the gearmotor sideways by loosening the 4 screws [B], to allow fixing.
- Fix with the screws [A].

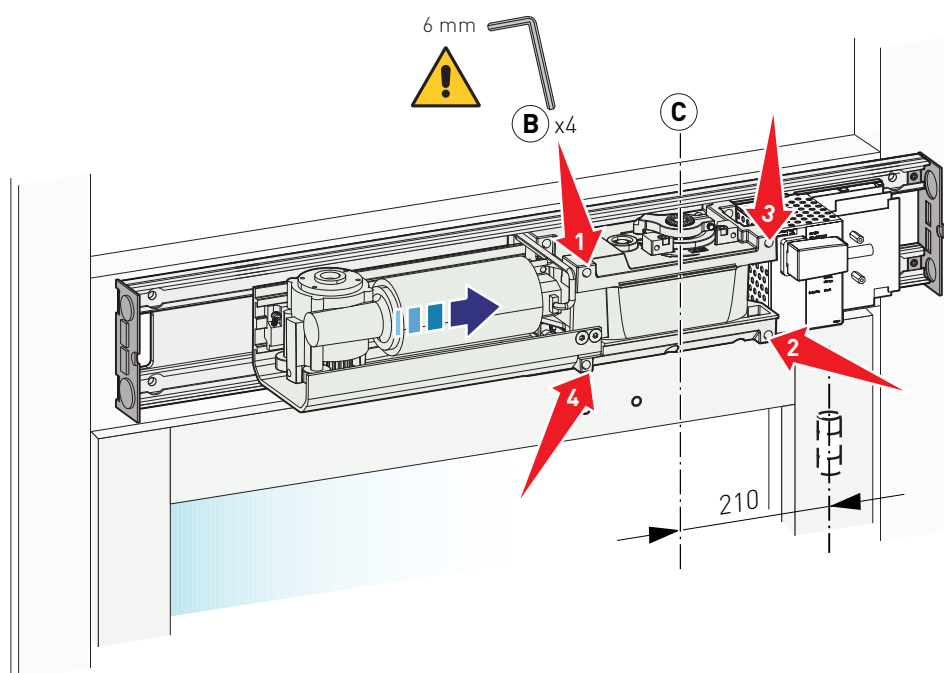

- Return the motor to its original position.
- Fix the motor by tightening the 4 screws [B] supplied, in the sequence shown in the figure.



Respect the measurement between the hinge and the gearmotor shaft output [C], as shown in the figure.

### 8.3 Fixing the arm

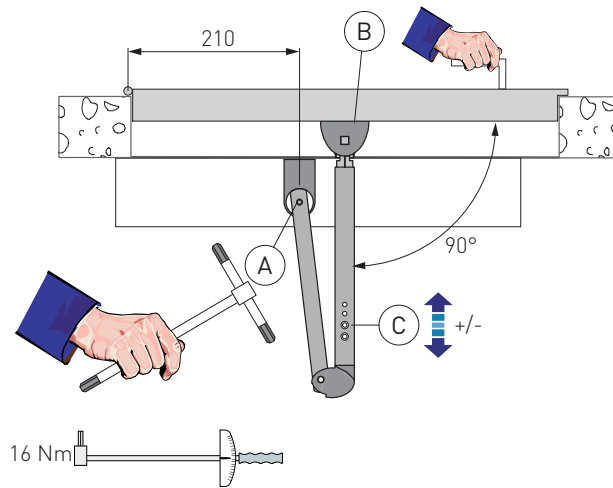

NB: open the door slightly and tighten the screw of the arm support seat [A] at 16 Nm (as shown in the figure).  
If a torque wrench is not available, use a hexagon wrench of the type shown in the figure, gripping it on the long side and tightening very firmly.

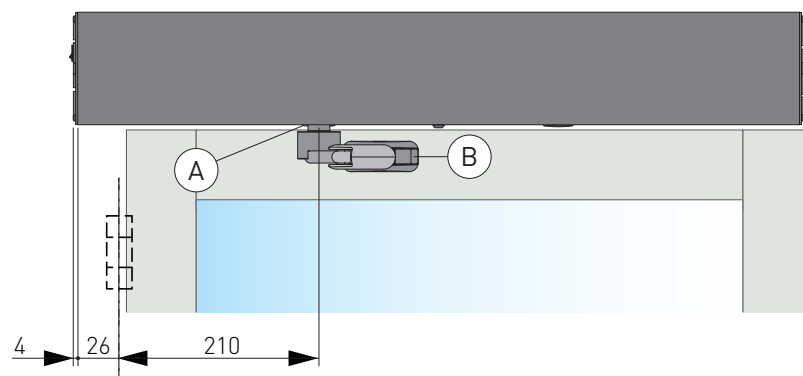

- Move the door manually to check it opens and closes correctly, without any friction.
- With the door closed, fix the arm to the arm support seat [A] on the automation.
- Fix the bracket [B] to the door wing, forming an angle of 90°. Lengthen or shorten the arm [C] if necessary.

### 8.4 Assembling the left-hand articulated arm.

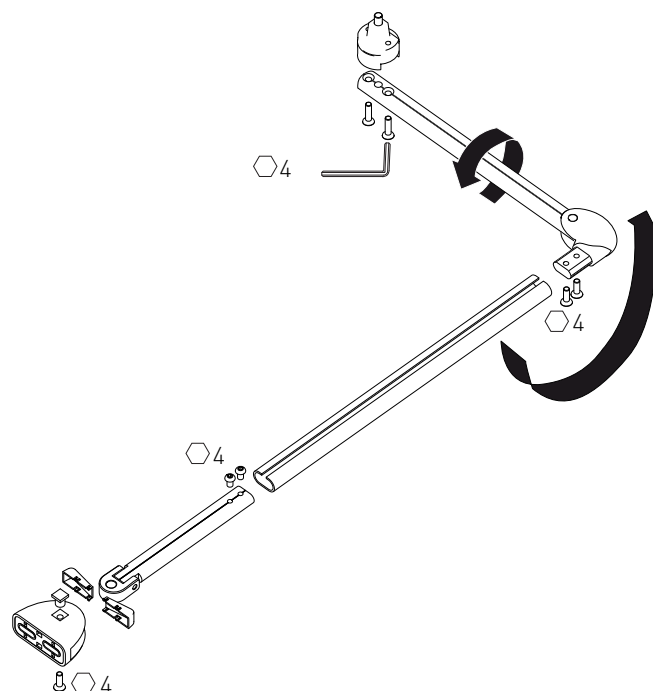

- In the case of automations with left-hand opening, you must invert the assembly of the articulated arm as shown in the figure.

## 9. Automation with articulated arm DAB805PSAF

**i** Before fixing the base plate [1], make holes for the cables to pass through.

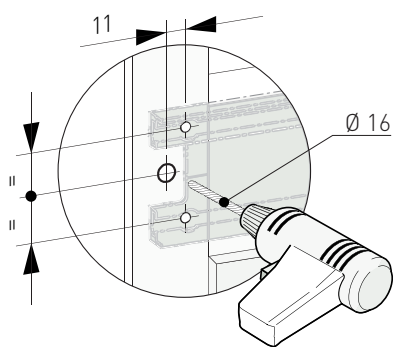

	X
DAB805PSAF	48
DAB805PSAF DAB805SE5F	98

Y	Extension
0-100	/
100-210	DAB805TFL
210-300	DAB805TFS DAB805TKJ

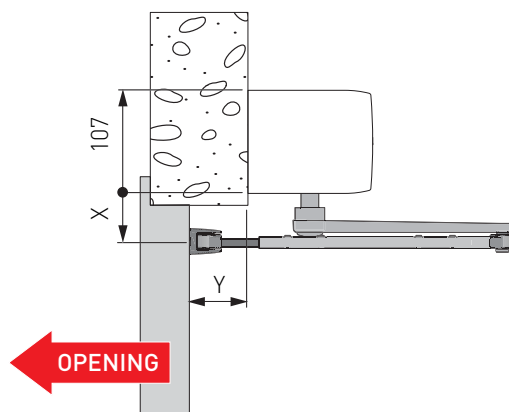

### 9.1 Set-up

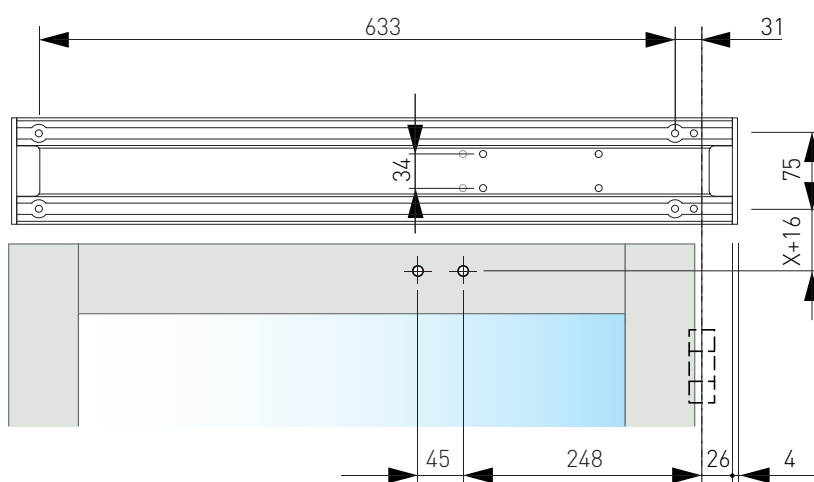
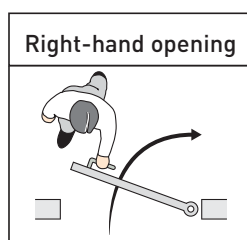
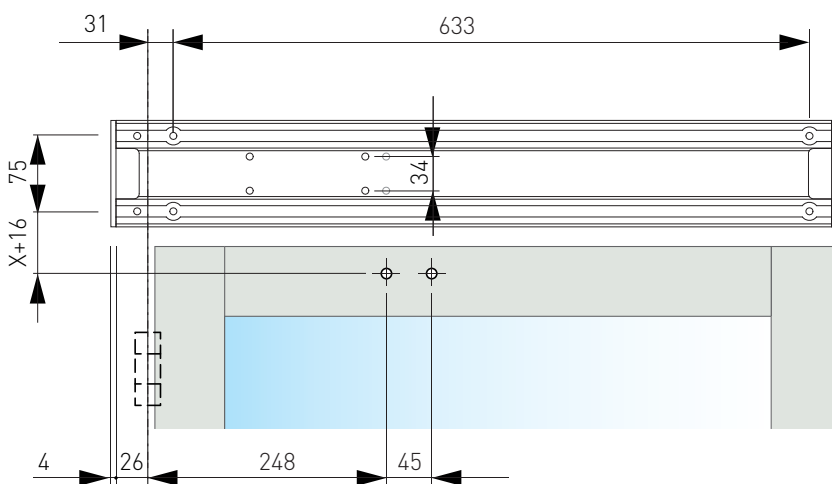
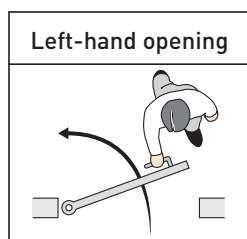

- Prepare the set-up for fixing the automation to the wall, respecting the measurements shown in the figures above (with reference to the hinge axis).
- Drill a hole in the door wing, in line with the fixing for the articulated arm.
- If necessary, use the DAB805SE5F extension to increase the X measurement between the automation and the arm fixing points.

## 9.2 Fixing the automation

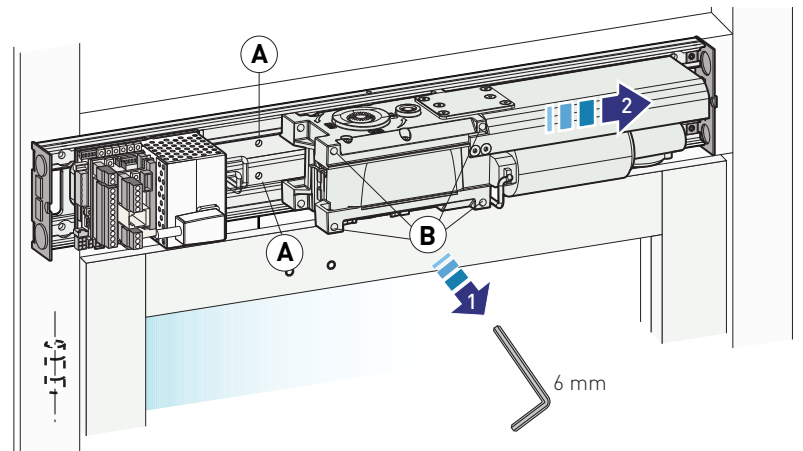
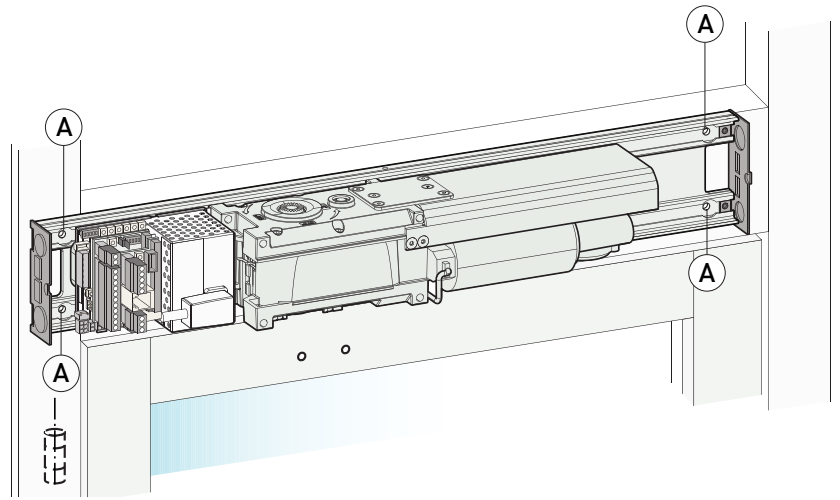
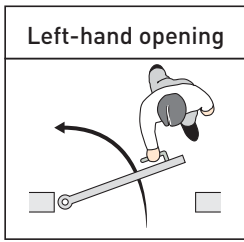

- Fix the automation in place using the screws [A]; tighten them firmly and evenly.
- Move the gearmotor sideways by loosening the 4 screws [B], to allow fixing.
- Fix with the screws [A].

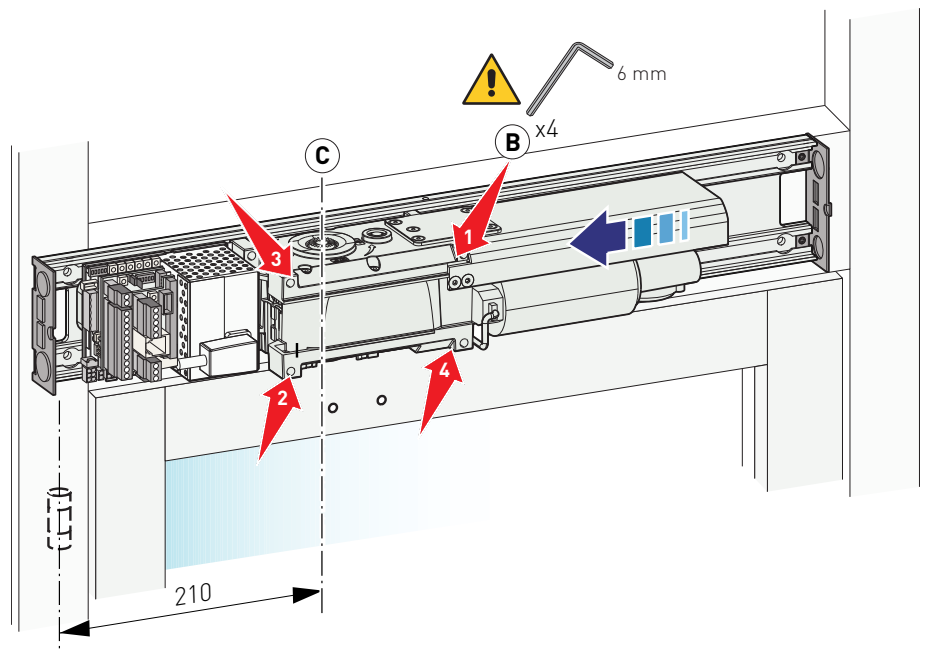

- Return the motor to its original position.
- Fix the motor by tightening the 4 screws [B] supplied, in the sequence shown in the figure.



Respect the measurement between the hinge and the gearmotor shaft output [C], as shown in the figure.

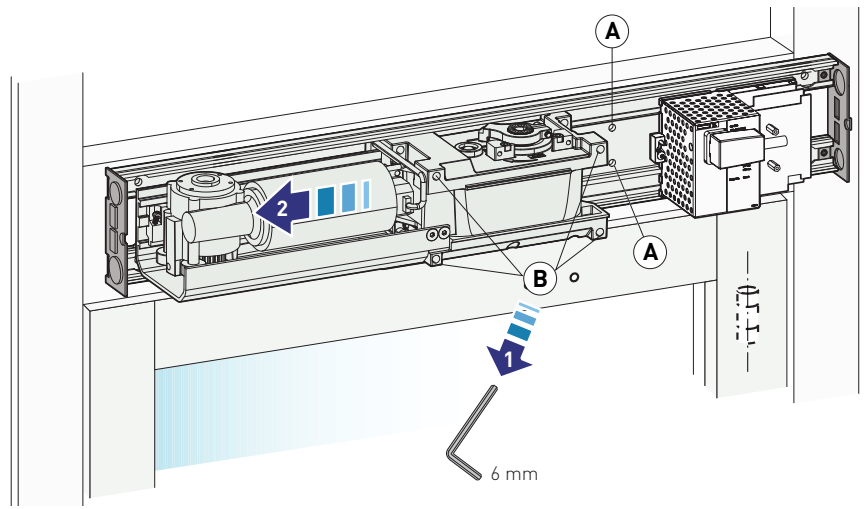
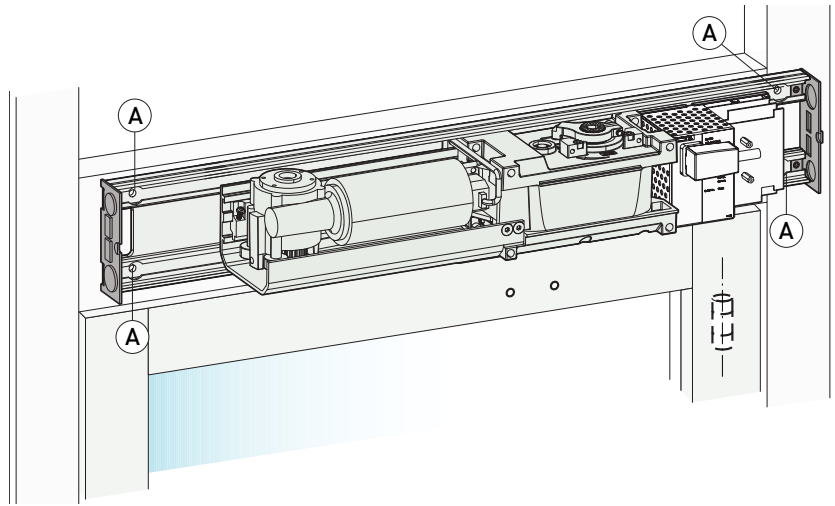
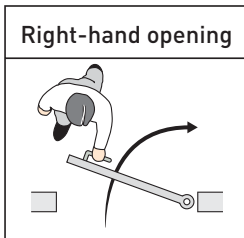

- Fix the automation using the screws [A], tightening them firmly.
- Move the gearmotor sideways by loosening the 4 screws [B], to allow fixing.
- Fix with the screws [A].

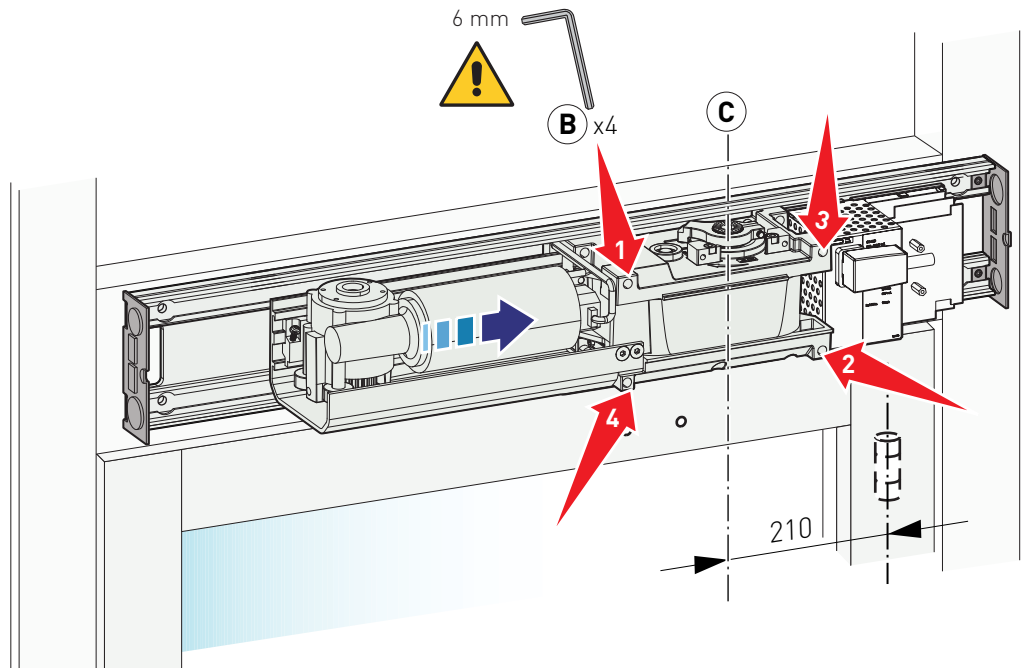

- Return the motor to its original position.
- Fix the motor by tightening the 4 screws [B] supplied, in the sequence shown in the figure.



Respect the measurement between the hinge and the gearmotor shaft output [C], as shown in the figure.

### 9.3 Fixing the arm

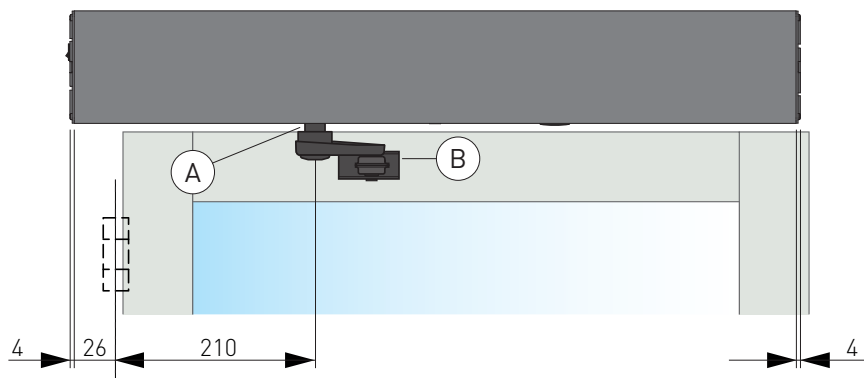
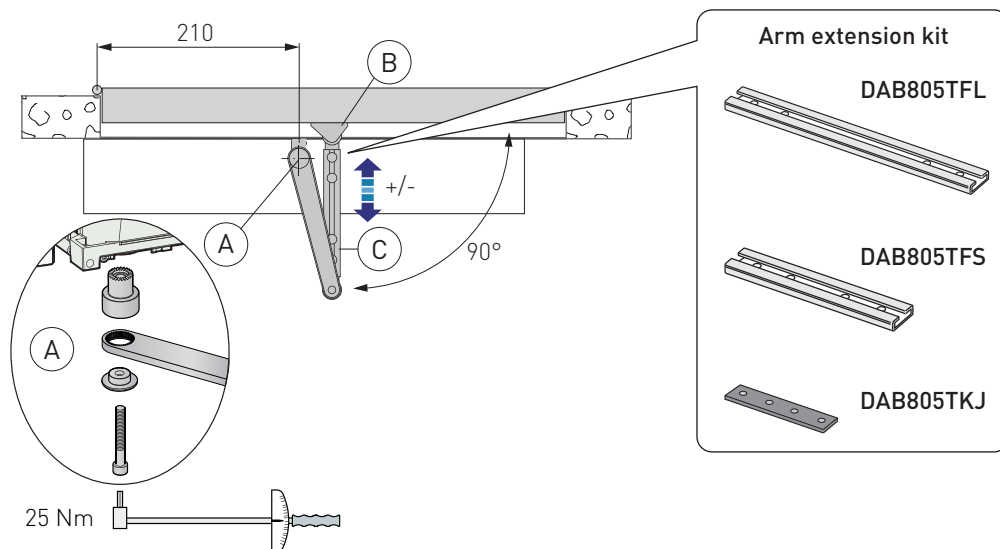

- Move the door manually to check it opens and closes correctly, without any friction.
- With the door closed, fix the arm to the arm support [A] on the automation.
- Fix the bracket [B] to the door wing, forming an angle of 90°. If necessary, lengthen (using the arm lengthening kit) or shorten the arm [C].

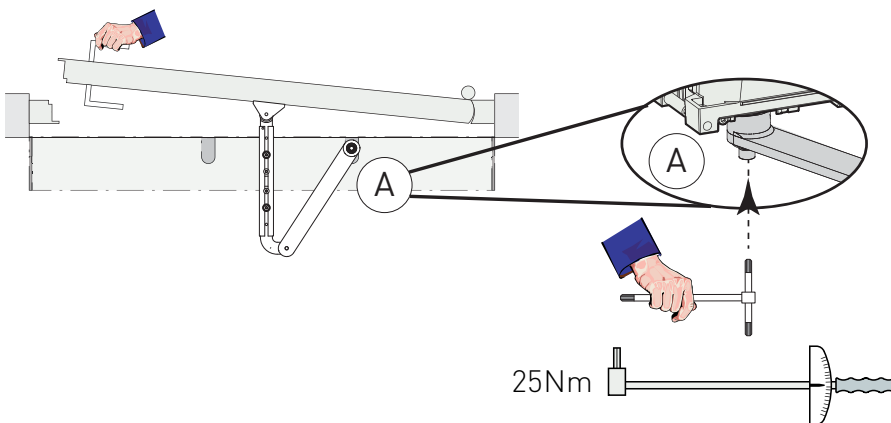

NB: open the door slightly and tighten the screw of the arm support seat [A] at 25 Nm (as shown in the figure).  
If a torque wrench is not available, use a hexagon wrench of the type shown in the figure, gripping it on the long side and tightening very firmly.

# 10. Automation with sliding arm DAB805PLA

Use the sliding arm for doors that open inwards (as seen from the automation side).

**i** Before fixing the base plate [1], make holes for the cables to pass through.

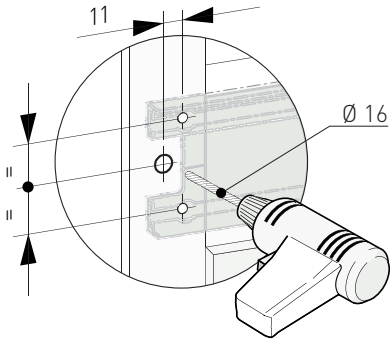

	X
DAB805PLA	50
DAB805PLA DAB805SE2	70
DAB805PLA DAB805SE5	100
DAB805PLA DAB805SE7	120

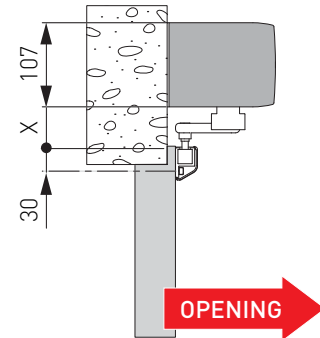

## 10.1 Set-up

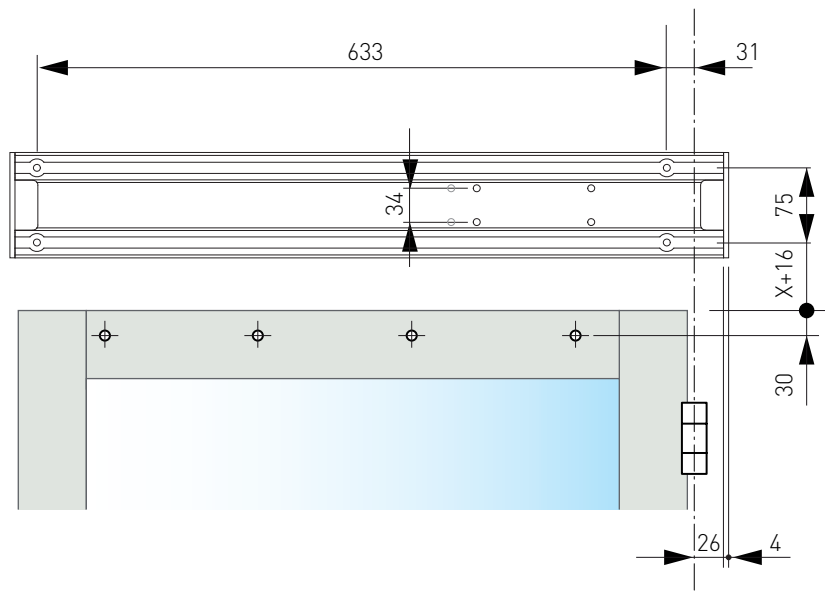
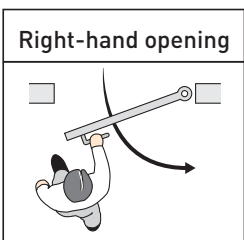
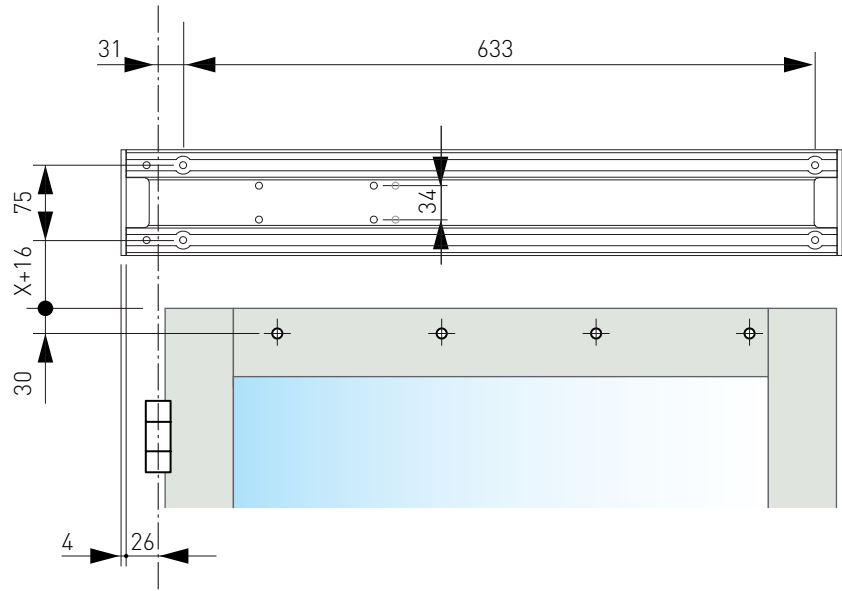
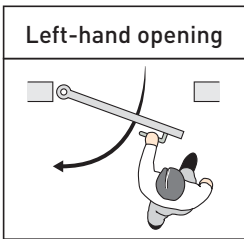

- Prepare the set-up for fixing the automation to the wall, respecting the measurements shown in the figures above (with reference to the hinge axis).
- Drill a hole in the door wing, in line with the fixing for the sliding arm.
- If necessary, use the DAB805SE2/SE5/SE7 extensions to increase the X measurement between the automation and the arm fixing points.

## 10.2 Fixing the automation

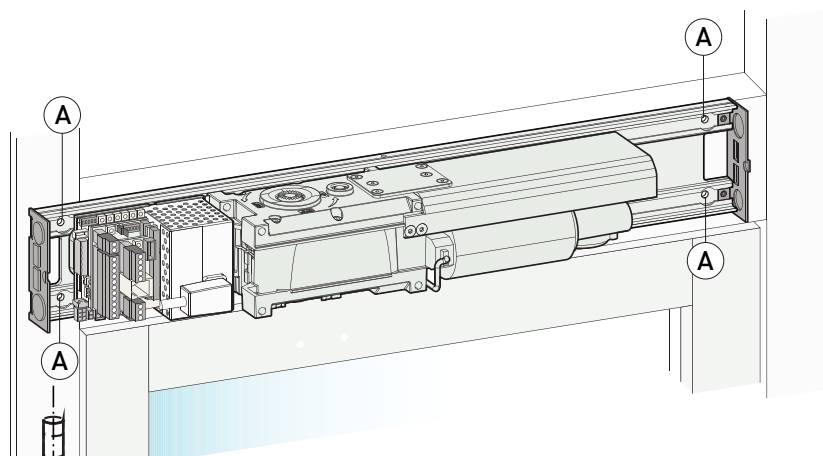
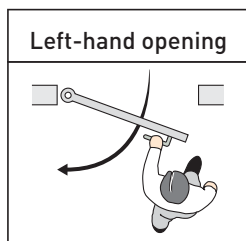

- Fix the automation using the screws [A], tightening them firmly.

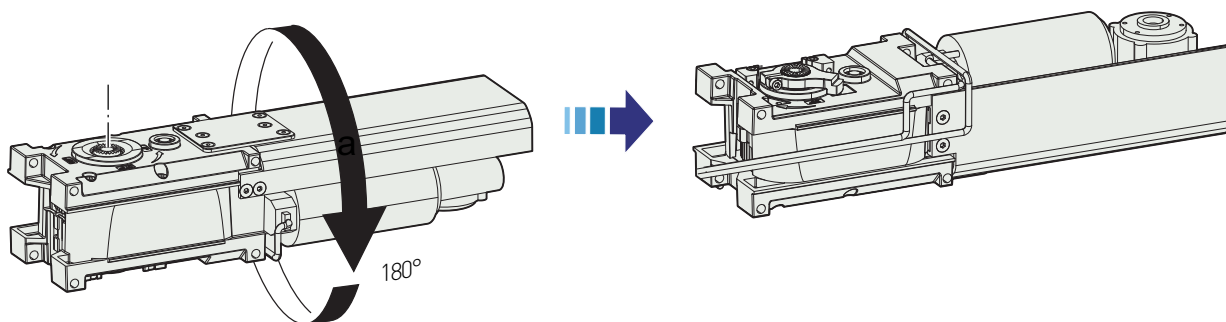
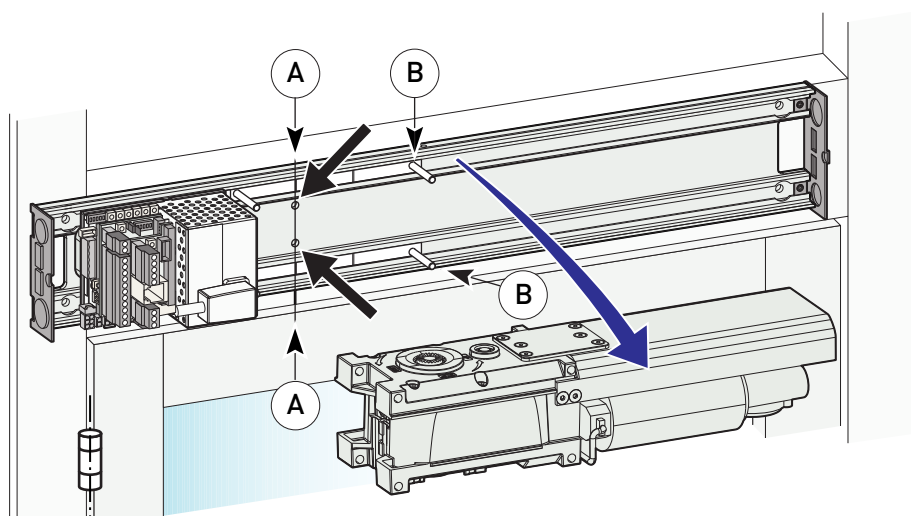

- Loosen the screws [B] that hold the motor in place. Remove the motor. Fix the base plate with the 2 screws [A].
- Rotate the motor 180°, as shown in the figure.

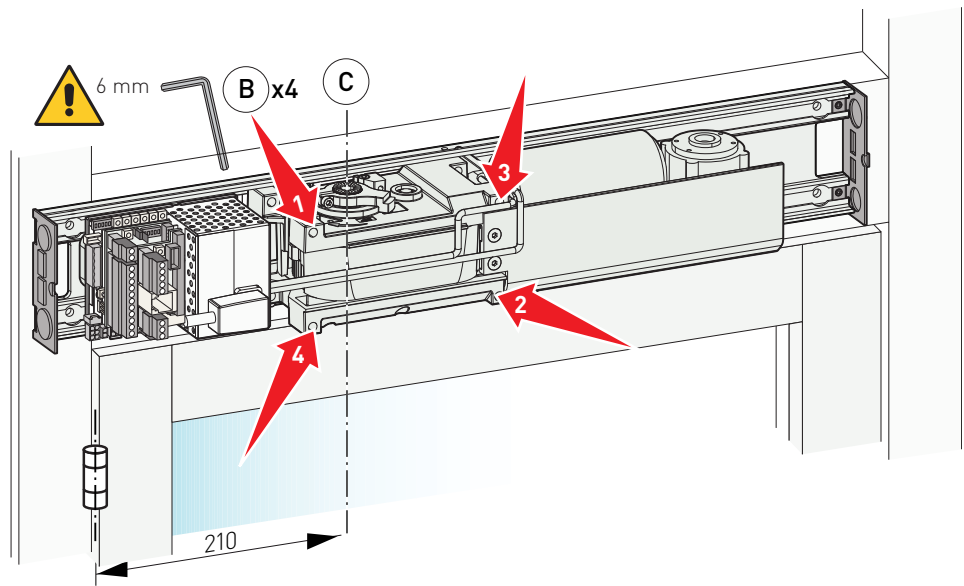

- Fix the motor by tightening the screws [B] supplied, in the sequence shown in the figure.



Respect the measurement between the hinge and the gearmotor shaft output [C], as shown in the figure.

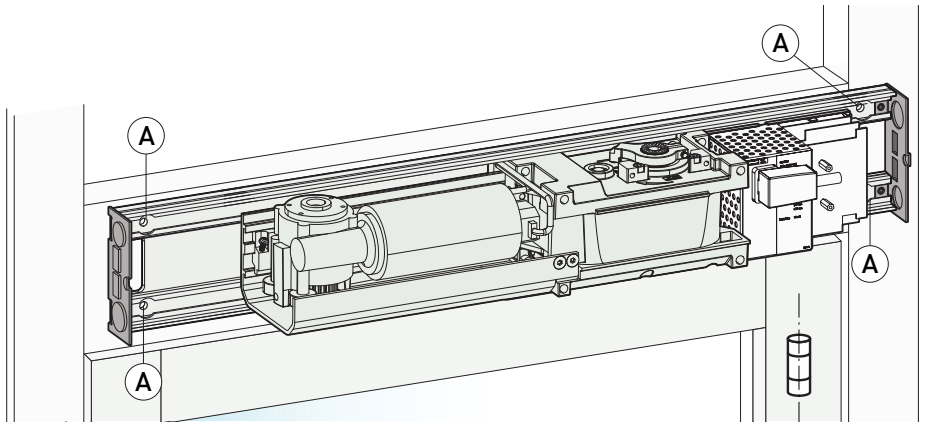
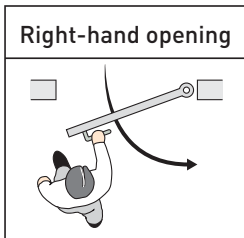

- Fix the automation using the screws [A], tightening them firmly.

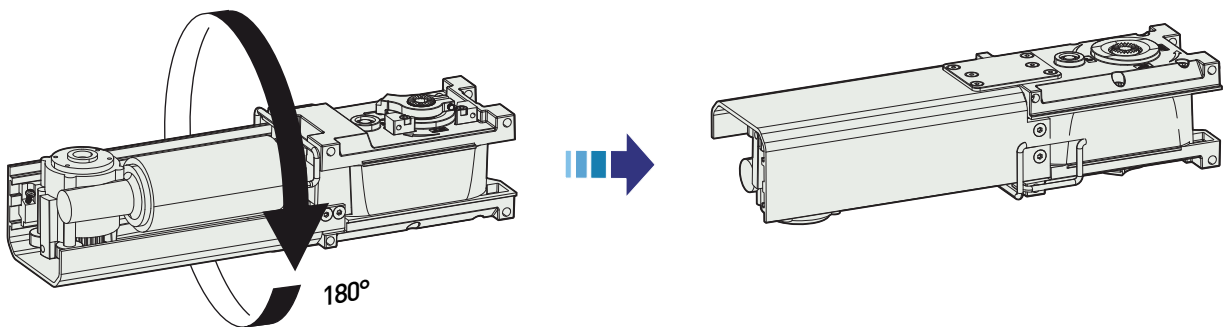
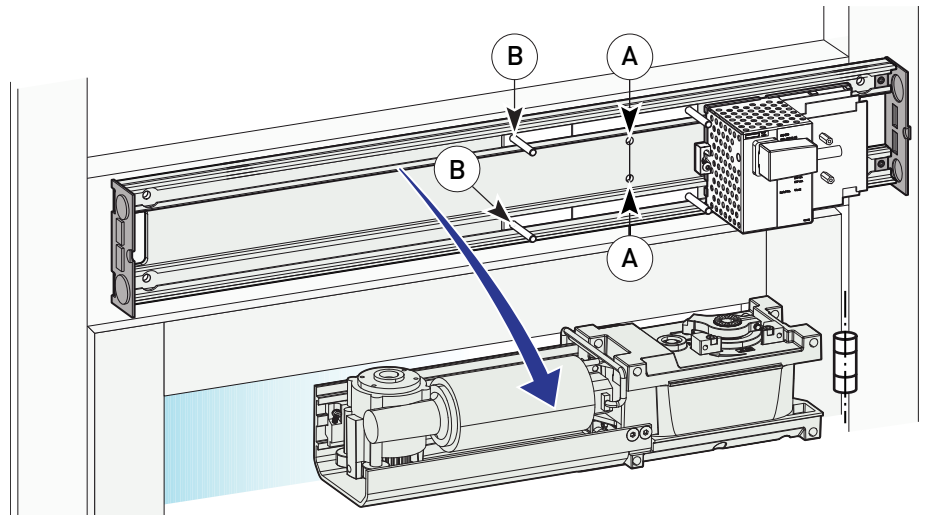

- Loosen the screws [B] that hold the motor in place. Remove the motor. Fix the base plate with the 2 screws [A].
- Rotate the motor 180°, as shown in the figure.

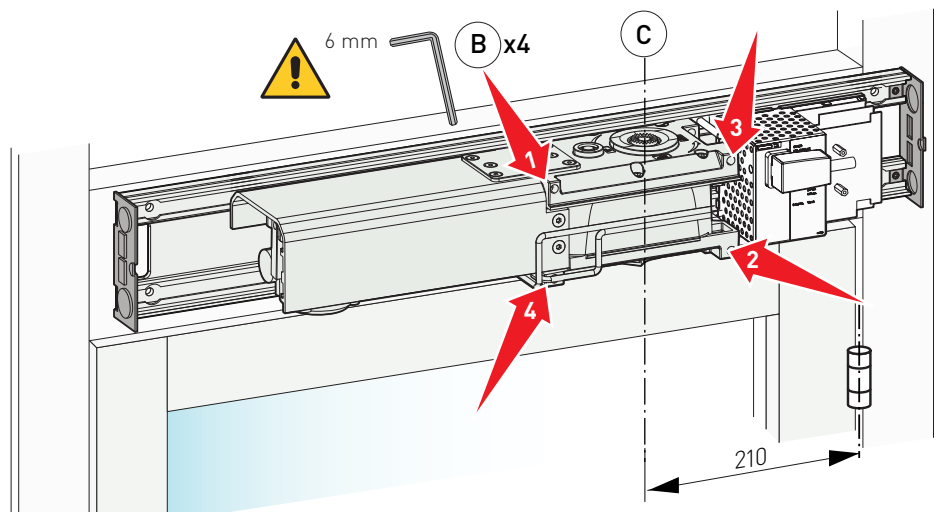

- Fix the motor by tightening the screws [B] supplied, in the sequence shown in the figure.

**i** Respect the measurement between the hinge and the gearmotor shaft output [C], as shown in the figure.

## 10.3 Fixing the sliding arm

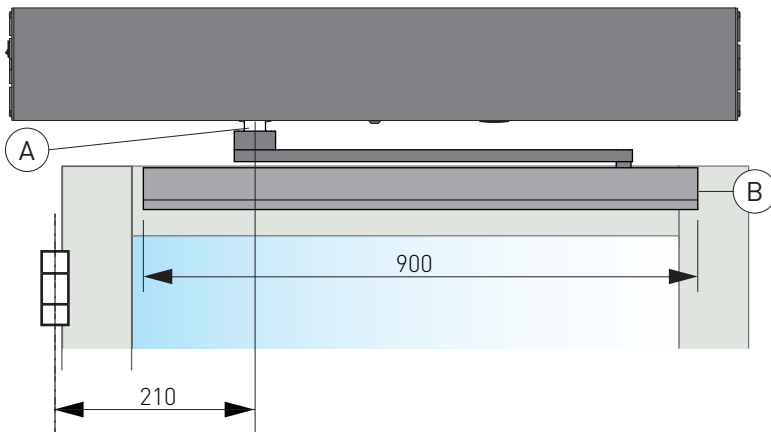
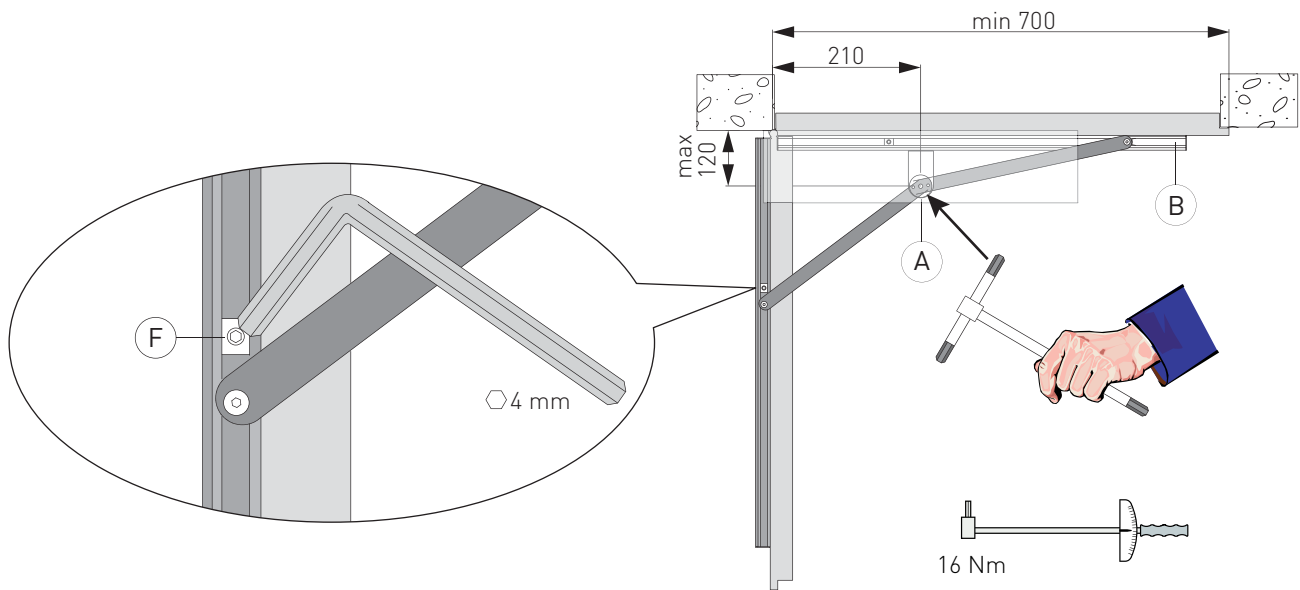

**NB:** open the door slightly and tighten the screw of the arm support seat [A] at 16 Nm (as shown in the figure).  
If a torque wrench is not available, use a hexagon wrench of the type shown in the figure, gripping it on the long side and tightening very firmly.

- Move the door manually to check it opens and closes correctly, without any friction.
- With the door closed, fix the arm to the arm support [A] on the automation.
- Fix the guide [B] to the door wing, cutting off the excess part if necessary.

## 10.4 Fixing the door stop

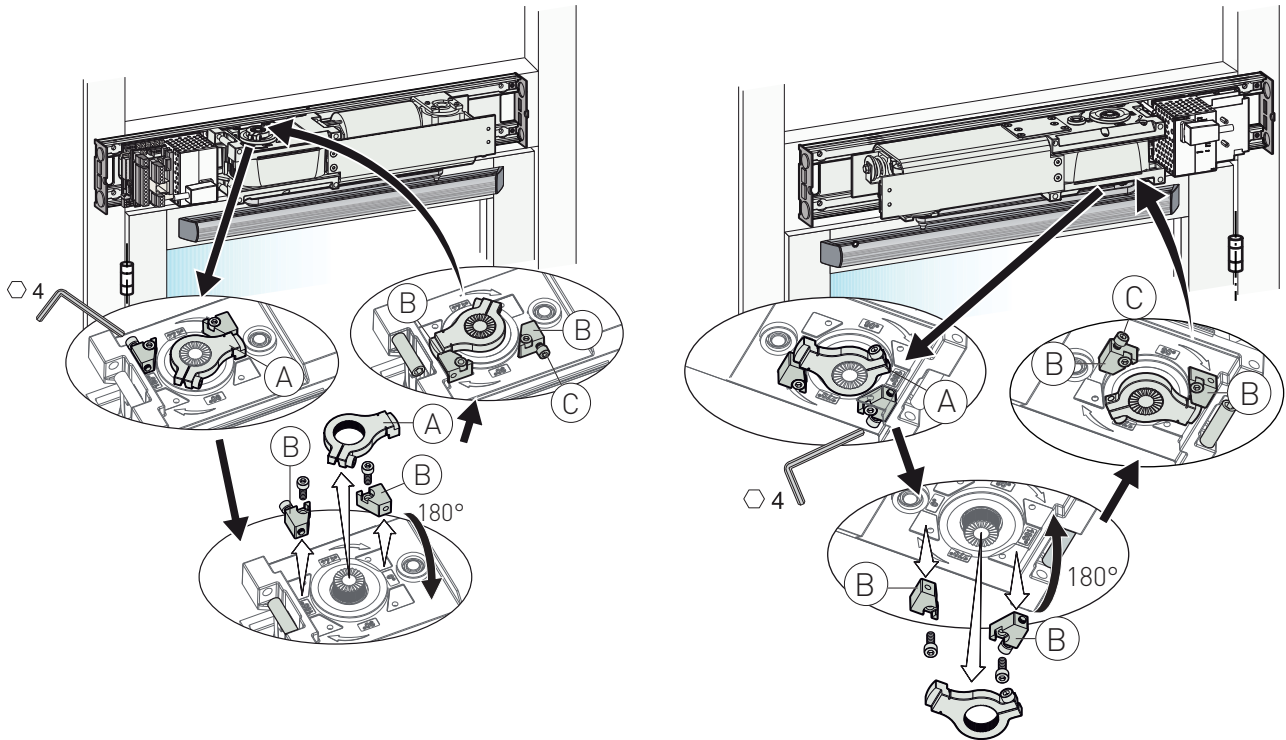
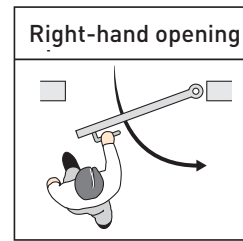
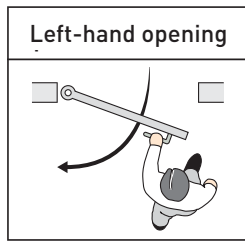

The following operations must be carried out with the arm installed and the door closed.

In the case of installations with a sliding arm, proceed as follows:

- Remove the limit switches [B]. Loosen the door stop [A] and move it to the unknurled part of the drive arm.
- Rotate the limit switches by 180°. Reposition them on the gearmotor as shown in the figure.
- Reposition the door stop [A] as shown in the figure.



The door stop [A] must be fitted as close to the closure limit switch [B] as possible.

- Move the door manually to check it opens and closes correctly, without any friction.
- Adjust the internal open door stop [F], as indicated in paragraph 10.3.

# 11. Connecting to the electricity supply

Before connecting the power supply, make sure the plate data correspond to that of the mains power supply.

An omnipolar disconnection switch with a contact opening distance of at least 3 mm must be fitted on the mains supply.

Check there is an adequate residual current circuit breaker and overcurrent cut-out upstream of the electrical system.

Use a H05RN-F 3G1,5 or H05RR-F 3G1,5 type electric cable.

In the section outside the automation, the connection to the mains power supply must be via an independent channel separate from the connections to the control and safety devices.

Make sure there are no sharp edges that may damage the power supply cable.

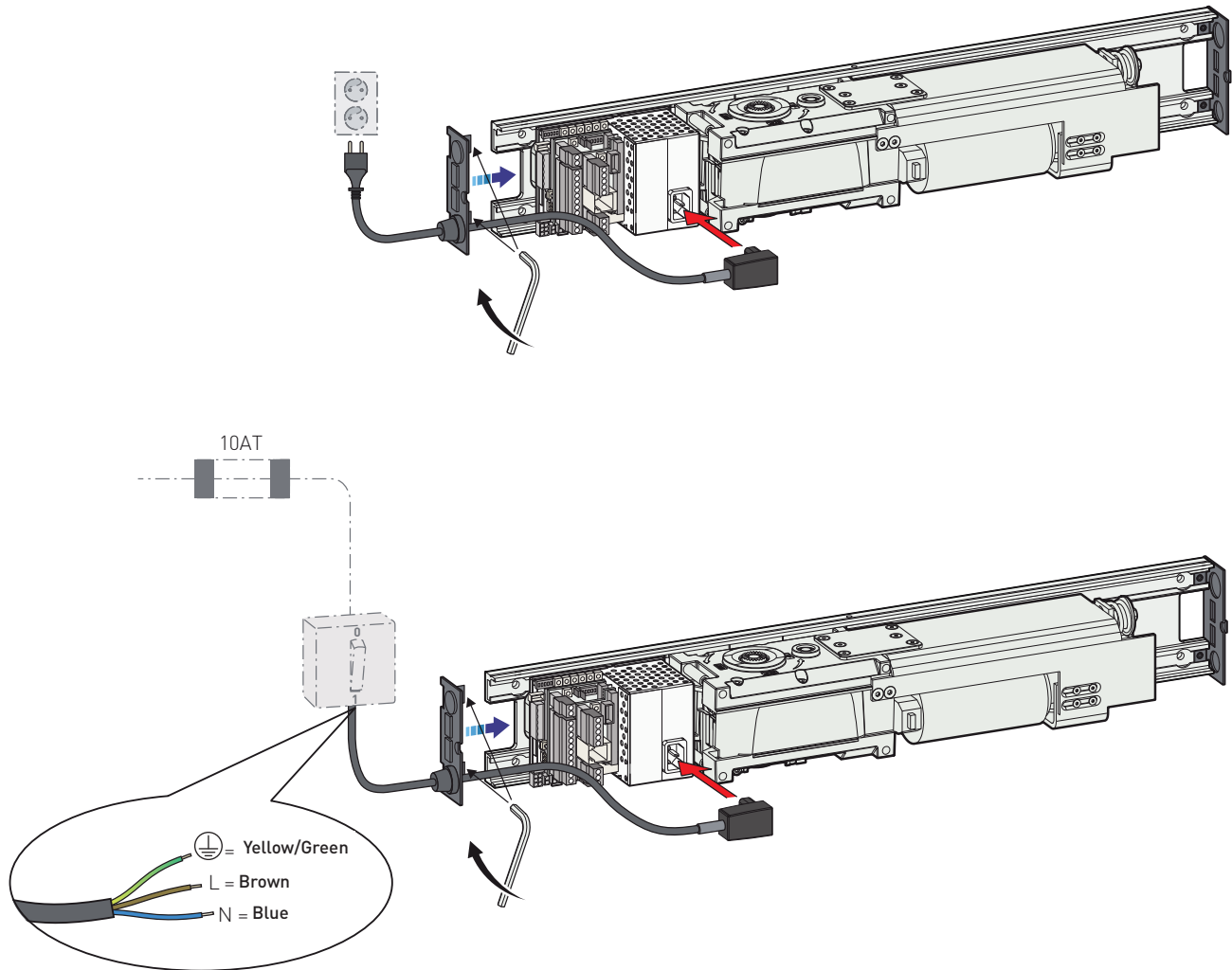

## 12. Starting up the door

Place the door in the closed position.



Rotate the SPTE trimmer on the control panel to 0° (if it is not already in this position).

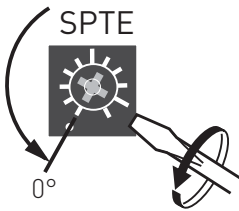

Turn on the power supply.

Gradually rotating the SPTE trimmer clockwise, the door opens electrically. Slowly bring it to the required open position, plus about 15 mm.

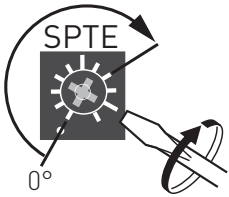

Loosen the door stop [A]. Move it to the unknurled part of the arm.

Insert the door stop [A] in the groove, as close as possible to the opening limit switch [B].

If necessary, make a fine adjustment with the screw [C] on the opening limit switch.

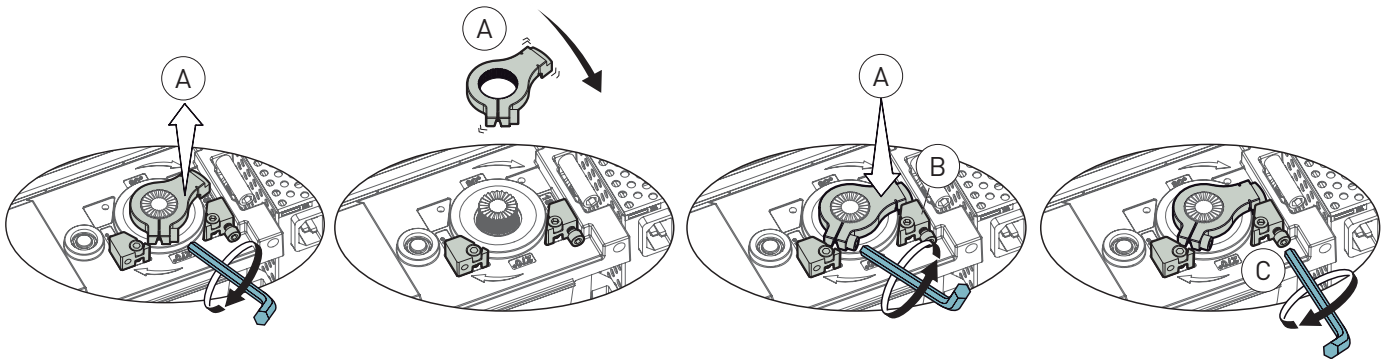

Close the door by rotating the SPTE trimmer to 0°.

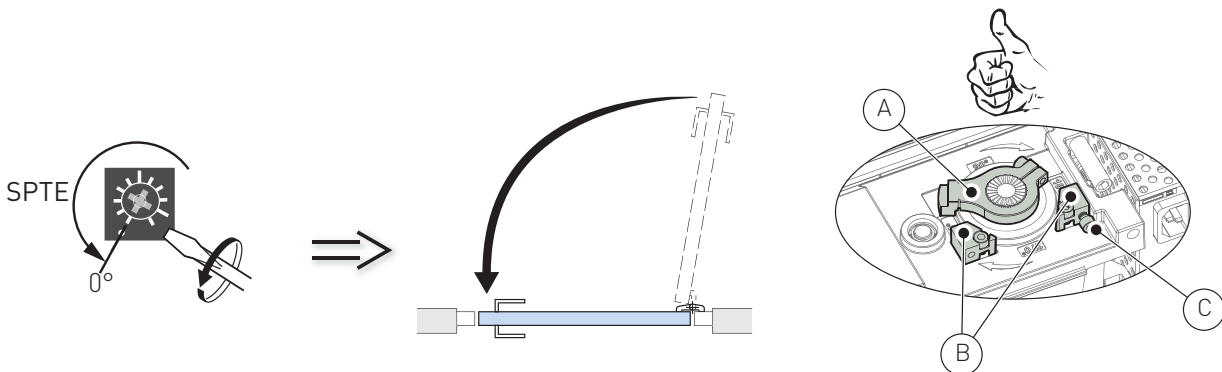

# 13. Electrical connections DAB105CU

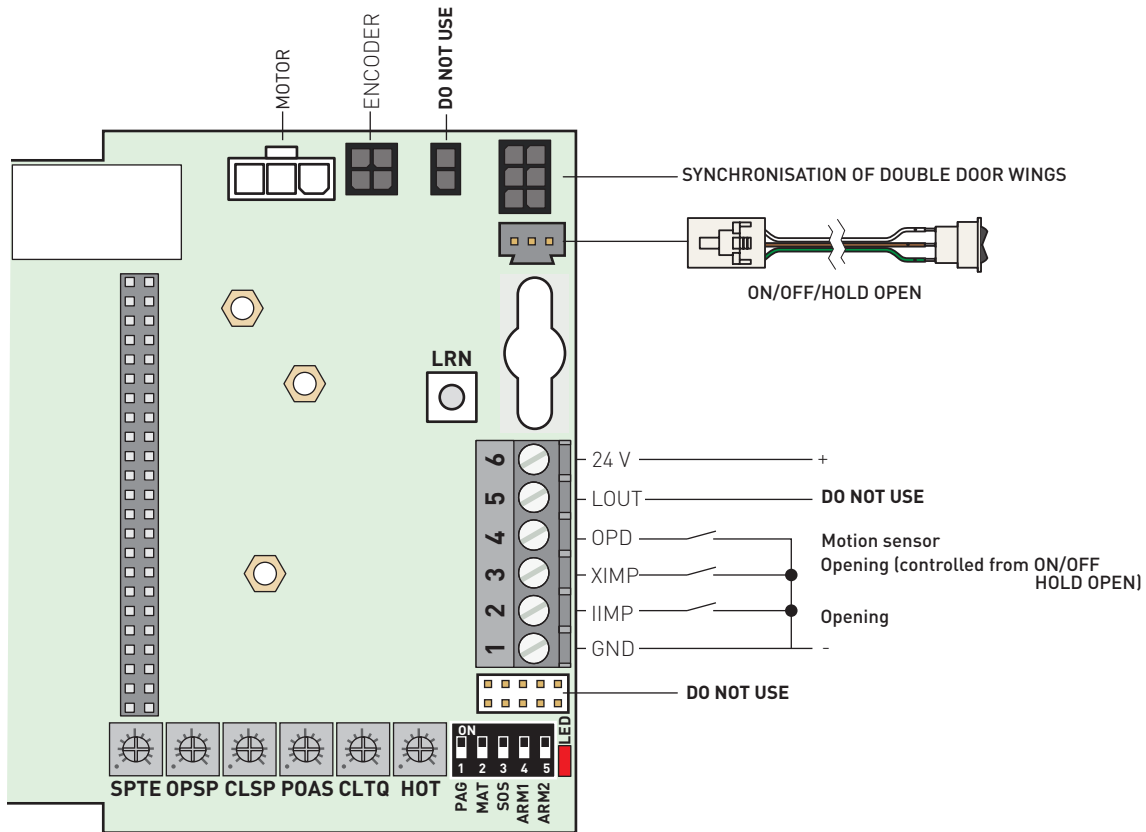

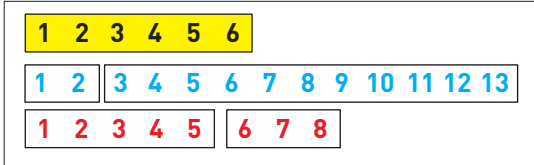

**i** Fix the label to the terminal board, taking care to apply it in the correct direction (see the figure above).









Optional extension units can be connected to the DAB105CU control panel: the DAB905ESE extension unit, or the DAB905ESA one, or both, depending on the required functions.

## 13.1 Commands

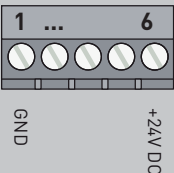
Contact	Function / Accessory	Description
1-2 GND-IIMP	NO OPENING - INNER SIDE	Contact closure activates the opening operation. The contact is always active if the ON-OFF-HOLD OPEN switch is present. The contact is controlled by the COM400MHB/MKB function selector switch (if present).
1-3 GND-XIMP	NO OPENING - OUTER SIDE, MANAGED BY THE ON- OFF-HOLD SWITCH	Contact closure activates the opening operation. The contact is only active if the ON-OFF-HOLD OPEN switch is present. DO NOT USE contact 1-3 or the ON-OFF-HOLD OPEN switch if the COM400MHB/MKB function selector switch is installed.
1-4 GND-OPD	NO OPENING SAFETY DEVICE	Contact closure prevents the door from opening (if closed) or closing (if open).
1-5 GND-LOUT	DO NOT USE	

Contact	Function / Accessory	Description
		<p>Automatic self-learning. When the door is started up, and on every spring tensioning variation, CLTQ trimmer variation, replacement of the extension units (DAB905ESE-DAB905ESA) or replacement of the electric lock / electric strike, it is necessary to perform an automatic self-learning operation.</p>
		<p> <b>Make sure the door is fully closed. Move away from the door as soon as you have pressed the LRN button. The door has no safety settings during the automatic self-learning procedure. The door could suddenly slam shut.</b></p>
LRN		<p>By pressing the LRN button, the door launches an opening/closing operation for the automatic self-learning of the positions and of the opening/closing stops.</p>
		<p> <b>DO NOT intervene during the self-learning procedure.</b></p>
		<p>During the closure phase, the spring pushes the door to acquire the door wing weight.</p> <p>By pressing the LRN button once, the door will open after 2 seconds. Press the LRN button twice to open the door immediately.</p> <p>In the case of double doors, the automatic self-learning operation must be carried out first on the MASTER door and then on the SLAVE door. The doors can be configured separately before connecting them with the synchronisation cable. In the case of door wing overlap and separate configurations, the MASTER door must be kept open until the SLAVE door has completed its own self-learning procedure.</p>

## 13.2 Outputs and accessories



Output	Description						
	<p>Output for the power supply to the accessories 24V <math>\overline{\text{DC}}</math> 400 mA max. NB: the maximum absorption of 400 mA corresponds to the sum of all the accessories installed.</p>						
<p><b>MOTOR</b></p> 	Motor connection						
<p><b>ENCODER</b></p> 	Encoder connection						
<p><b>ON/OFF</b></p> 	DO NOT USE						
<p><b>SYNC</b></p> 	<p>Connection for cable for synchronisation between two swing doors. For details about the operation, refer to the "SYNCHRONISED DOORS" chapter.</p>						
<p><b>ON/OFF/HOLD</b></p> 	<p>Connection of the ON/OFF/HOLD switch</p> <table border="1"> <tr> <td>ON</td> <td>The IIMP and XIMP opening contacts are enabled.</td> </tr> <tr> <td>OFF</td> <td>The XIMP opening contact is excluded.</td> </tr> <tr> <td>HOLD OPEN</td> <td>Door open.</td> </tr> </table>	ON	The IIMP and XIMP opening contacts are enabled.	OFF	The XIMP opening contact is excluded.	HOLD OPEN	Door open.
ON	The IIMP and XIMP opening contacts are enabled.						
OFF	The XIMP opening contact is excluded.						
HOLD OPEN	Door open.						
<p><b>MOTION SENSOR</b></p> 	DO NOT USE						

## 13.3. Adjustments

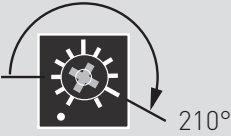
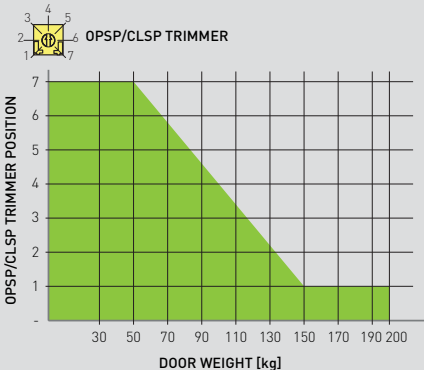
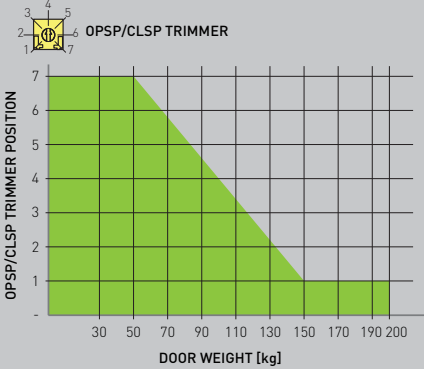
### Trimmer





Trimmer	Description
<b>SPTE</b>  	<p><b>Door start-up</b> The SPTE trimmer is used to make adjustments for the acquisition of the opening/closing stops when the door starts up.</p> <p><b>Spring tension adjustment</b> The spring pre-tensioning is factory-set at 210°.</p> <div style="background-color: #00AEEF; color: white; padding: 5px; border: 1px solid white;"> <p><b>i</b> The maximum pre-tensioning of the spring is 210°. A greater tension could damage the spring or overheat the motor.</p> </div> <p>To reduce/increase the pre-tensioning:</p> <ul style="list-style-type: none"> <li>• Loosen and remove the door stop (see chapter 10)</li> <li>• Rotate the trimmer clockwise until the door opens at 45°</li> <li>• Loose the fixing screw of the actuation arm</li> <li>• Move the door towards the open position to reduce the spring tension</li> <li>• Move the door towards the closed position to increase the spring tension (this operation is only possible if the spring has a pre-load less than the factory setting (210°) and no more than 210°).</li> <li>• Tighten the fixing screw of the actuation arm</li> <li>• Rotate the trimmer to minimum</li> <li>• Open the door to the required open position plus about 15 mm, by rotating the trimmer clockwise</li> <li>• Fix the door stop. For the fine adjustment, refer to chapter 10.</li> <li>• Rotate the trimmer to minimum</li> <li>• Press the LRN button to begin the door self-learning procedure</li> </ul>
<b>OPSP</b>	<p><b>Adjustment of the opening speed time (from 3 to 6 s).</b> Rotate the trimmer clockwise to increase the opening speed. ATTENTION. The opening and closing speeds are regulated according to the weight of the wing, as shown in the following diagram.</p> 
<b>CLSP</b>	<p><b>Adjustment of the closing speed time (from 3 to 6 s).</b> Rotate the trimmer anticlockwise to reduce the closing speed. ATTENTION. The opening and closing speeds are regulated according to the weight of the wing, as shown in the following diagram.</p> 
<b>POAS</b>	<p><b>Adjustment of the servo-assisted movement during the manual opening of the door.</b> With the trimmer at its minimum, the door is not servo-assisted. By rotating the trimmer clockwise, the motor increases the servo-assistance when the door is opened manually.</p>
<b>CLTQ</b>	<p><b>Closing force adjustment</b> With the trimmer at its minimum, the door closes with the force of the spring. By rotating the trimmer clockwise, the motor increases the closing force. Increase the closing force on doors installed in environments with different pressure levels or subject to strong gusts of wind.</p>
<b>HOT</b>	<p><b>Adjustment of the automatic closing time (from 1.5 to 30 s)</b> Adjust the time that passes between the end of the opening operation and the start of the closing operation. The count begins with the door fully open.</p>

## Dip-switches



DIP	Description	OFF 	ON 
DIP1 - PAG	<b>Push &amp; Go</b> The manual pushing of the door activates an automatic opening operation. When the door is closed, a closure thrust is maintained by the motor or the spring.	Disabled	Enabled
DIP2 - MAT	DO NOT USE		
DIP3 - SOS	<b>Obstacle during opening</b>	<b>Stall</b> If an obstacle is detected during the opening operation, the door continues to push and then closes after the time lapse set with the HOT trimmer.	<b>Stop</b> If an obstacle is detected during the opening operation, the door stops its movement and closes after 2 s.
DIP4 - ARM1 DIP5 - ARM2	Selection of the arm type. See the following table.		













The factory configuration is set for an articulated arm.  
To alter DIP4 and DIP5, disconnect the mains power supply.  
Select the arm type.  
Restore the power supply.

Articulated arm DAB805PSA-PSAF (FACTORY SETTING)	DIP4 OFF 	DIP5 OFF 
Sliding arm DAB805PLA-PLAB 3-lever arm DAB805PLAT	DIP4 ON 	DIP5 OFF 

## Signals

LED	ON 	OFF 	FLASHING 
LED	Normal operation	No mains power supply	Alarm (see the alarms table)

## Alarms

 LED	CAUSE	SOLUTION
(1) 	Short-circuit Incorrect sensor detection	Check for short-circuiting or a damaged sensor
(2) 	Faulty battery	Replace the battery
(3) 	Faulty control panel	Replace the control panel
(4) 	Encoder error	Check the encoder cable. Manually open and close the door, then check the automatic function. If the problem persists, replace the control panel.
(5) 	Faulty blocking device	Check for short-circuiting in the blocking device Replace the blocking device
	Faulty DAB905ESE unit	Replace the DAB905ESE unit
(6) 	Synchronisation cable not connected, or faulty (parallel doors only)	Connect the cable
		Replace the cable
(7) 	SLAVE control panel faulty (parallel doors only)	Check the frequency of the flashes on the SLAVE LED, and adopt the necessary measures on the basis of this table
(8) 	Overheated motor	Wait for the motor to cool down
(9) 	Door blocked or repetitive command	Activate and deactivate the command

# 14. Pre-configured parameters

The DAB105 automation has 10 groups of pre-configured system-loaded parameters.

The group of parameters set in the factory corresponds to number 1.

To modify the group of parameters:

1. Disconnect the batteries (if installed).
2. Disconnect the mains power supply.
3. Press the LRN self-learning button, and keep it pressed.
4. Enable the power supply - the LED will light up 3s 5s. Release the LRN self-learning button - the LED will switch off.
5. The LED flashes for a number of times corresponding to the number of the group of parameters (see the table).
6. Press the LRN button to pass to the next group of parameters after the set one. When you have reached the maximum limit of the parameters, you will restart from number 1.
7. Press the LRN button until you reach the required group of parameters.
8. Disconnect the mains power supply.
9. When the mains power supply is reconnected, the automation will use the new group of parameters.

Parameter group	1	2	3	4	5	6	7	8	9	10
Time of door open contact 3-5 ESE card (a)	15 min	endless	15 min	15 min	15 min	15 min	15 min	15 min	15 min	15 min
Battery use	Energy savings	Energy savings	Continuity	Energy savings	Energy savings	Energy savings	Energy savings	Energy savings	Energy savings	Continuity
Block mode with KILL command active	Blocked	Blocked	Blocked	Block managed by selector	Blocked	Blocked	Blocked	Blocked	Block managed by selector	Blocked
Obstacle during closure (b)	Closure	Closure	Closure	Closure	Reversal	Closure	Closure	Closure	Closure	Reversal
Motion sensor installed on synchronised doors. (c)	Separate detection	Separate detection	Separate detection	Separate detection	Separate detection	Common Limit	Separate detection	Separate detection	Separate detection	Separate detection
Block attempt on closure (d)	Enabled	Enabled	Enabled	Enabled	Enabled	Enabled	Disabled	Enabled	Enabled	Enabled
O/C command opening/closing (e)	TWO-WAY mode	TWO-WAY mode	TWO-WAY mode	TWO-WAY mode	TWO-WAY mode	TWO-WAY mode	TWO-WAY mode	TWO-WAY / DOOR CLOSED / ONE-WAY mode	TWO-WAY mode	TWO-WAY mode
Configuration of emergency closure contact (KILL)	NO	NO	NO	NO	NO	NO	NO	NO	NC	NO

**NOTES:**

- (a) If the door stays open following an O/C open command, the control panel will launch a closure command after 15 minutes of inactivity.
- (b) If set in "CLOSURE" mode, the automation will stop if an obstacle is detected.  
If set in "REVERSAL" mode, the automation will re-open. It continues to attempt the closure operation until the obstacle is removed.  
With parameters set on 1 (factory setting), if there is a problem with block coupling during the closure phase, the door will attempt to enable the coupling twice in automatic mode, then once more in manual mode. This function can be disabled (see Parameter 7).
- (c) In the case of synchronised doors, the motion sensor can intervene independently on each door, or simultaneously.
- (d) If there is a problem with block coupling during the closure phase, the door will again close and attempt to enable the coupling.
- (e) With the ON/OFF/HOLD switch, the O/C command is always active except in the "HOLD - Door open" position.  
With the program selector, the O/C command usually functions in TWO-WAY mode.  
With Parameter 8 selected, the O/C command functions in TWO-WAY / ONE-WAY / DOOR CLOSED mode.

# 15. Door requisites for Low Energy use

The DAB105 automation is factory supplied with the Low Energy setting enabled. If necessary, adjust the OPSP and CLSP trimmers so that the opening and closing times are the same or longer than those indicated in the table in accordance with DIN 18650-2 (the information in brackets refers to EN16005:2012 and ANSI 156.19).

The table shows the minimum opening times for opening of up to 80° and the minimum closing times for openings from 90° to 10°.

		Door wing weight [kg]				
		50	60	70	80	90
Door wing length [mm]	750	3.0 s (3.0 s)	3.2 s (3.0 s)	3.2 s (3.0 s)	3.3 s (3.0 s)	3.5 s (3.5 s)
	850	3.1 s (3.0 s)	3.1 s (3.0 s)	3.2 s (3.5 s)	3.4 s (3.5 s)	3.6 s (4.0 s)
	1000	3.2 s (3.5 s)	3.4 s (3.5 s)	3.7 s (4.0 s)	4.0 s (4.0 s)	4.2 s (4.5 s)
	1200	3.8 s (4.0 s)	4.2 s (4.5 s)	4.5 s (4.5 s)	4.8 s (5.0 s)	5.1 s (5.5 s)

Or modify the classifications as shown in the table.

1. Disconnect the batteries (if installed).
2. Disconnect the mains power supply.
3. Press the LRN self-learning button, and keep it pressed. Enable the power supply.
4. The LED will light up .
5. Release the LRN self-learning button - the LED will switch off.
6. The LED flashes as many times as the classification number (see table).
7. Press the LRN button to pass to the next classification number after the set one.
8. Press the LRN button until you reach the required classification.
9. Disconnect the mains power supply.
10. When the mains power supply is reconnected, the automation will use the new setting.

CLASSIFICATION	1 - Maximum performance	2 - Low energy (factory setting)
Standard	/	In accordance with DIN18650-2 (EN16005:2012)
Opening speed	2.5-12 s	Automatic limit 3-12 s
Closing speed	4-12 s	Automatic limit 4-12 s

The maximum setting for the opening speed and closing speed is automatically limited to the value indicated in the table; consequently, the speed may only be reduced.



Launch the automatic self-learning procedure (LRN button) after every parameter setting modification.

## 16. Example of an application with a standard control panel

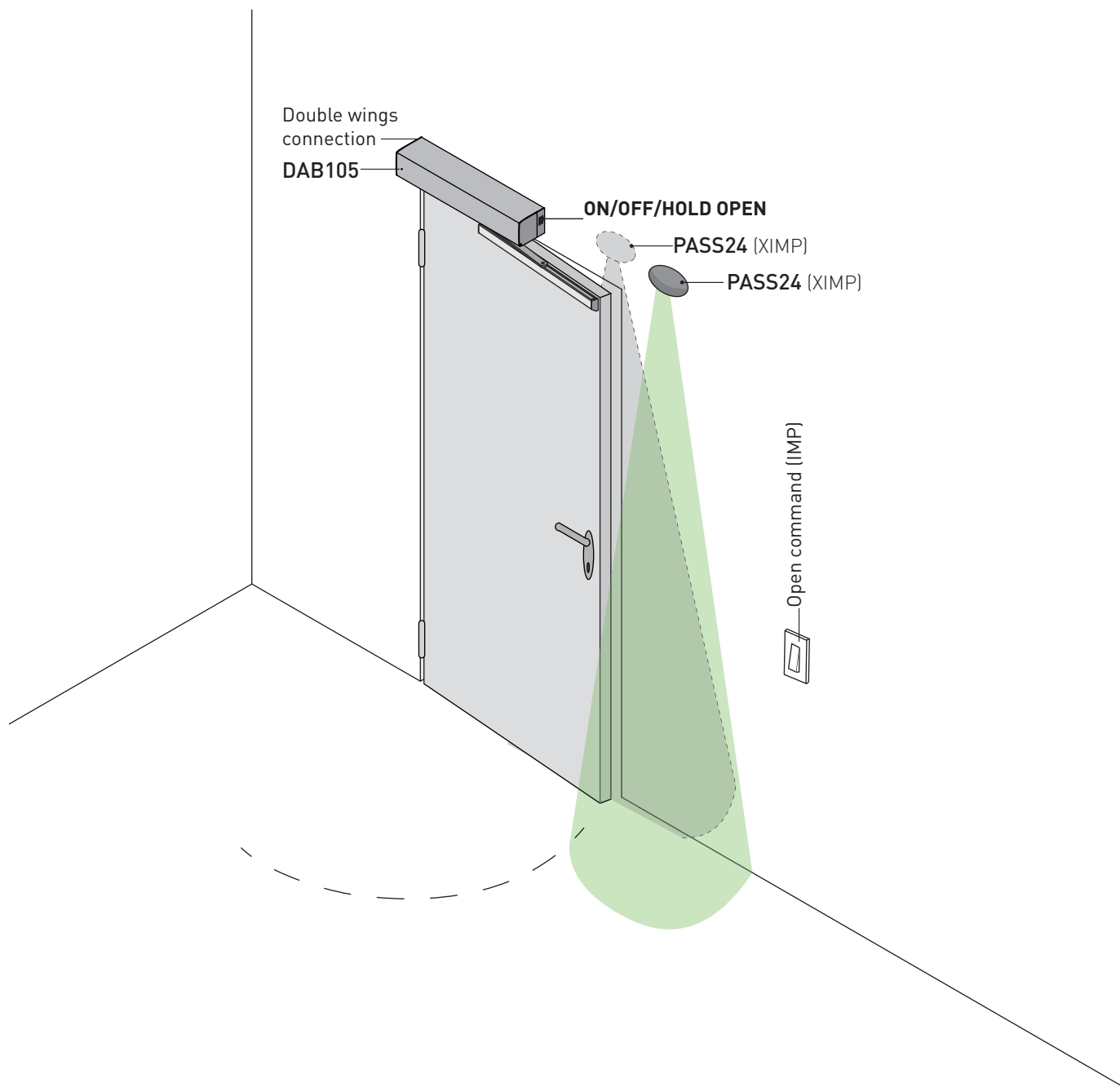

# 17. Extension unit DAB905ESE (optional)

There is a command extension card for managing the electric lock / electric strike, function selector, batteries, key selector switch and night-time closure.

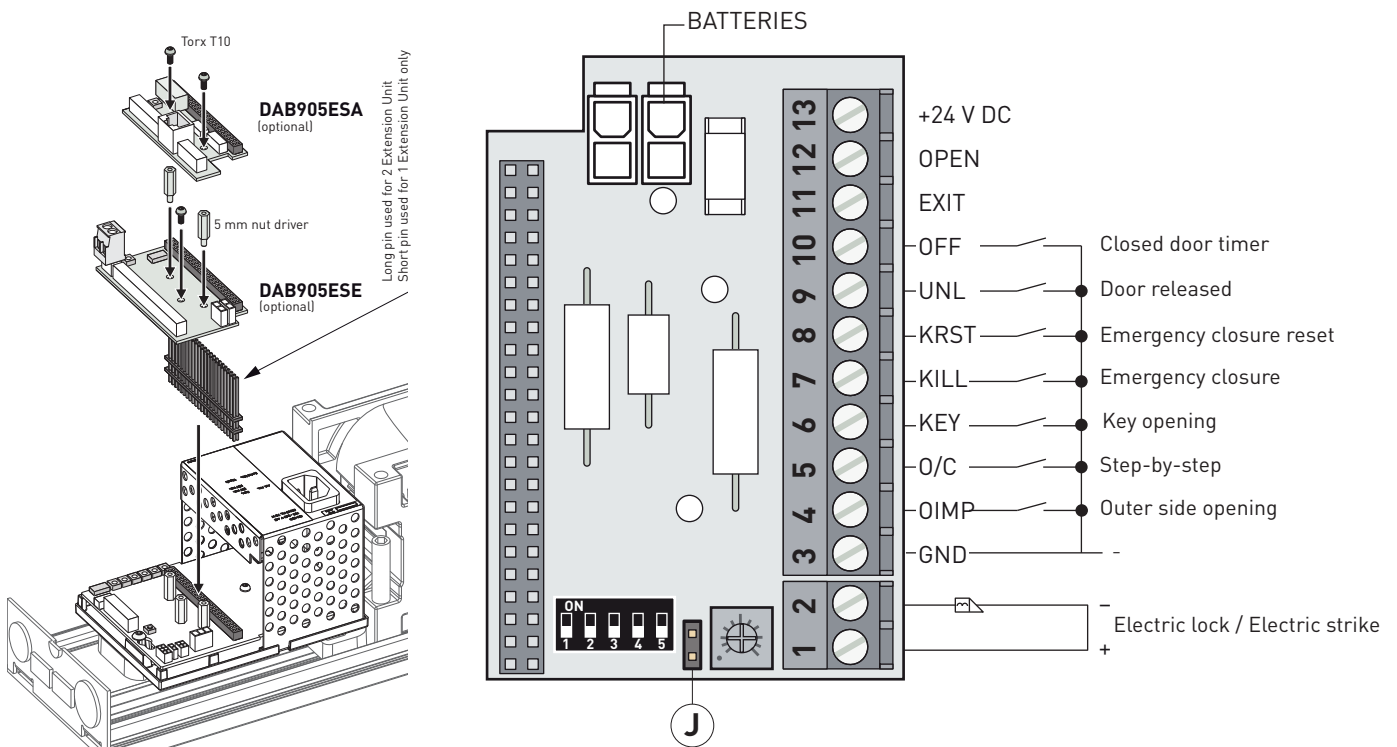

**i** Fix the label to the terminal board, taking care to apply it in the correct direction (see the figure above).

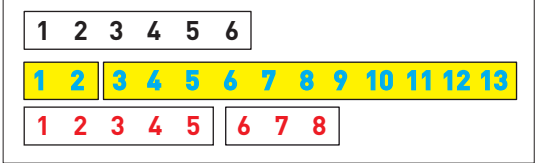



## 17.1 Commands

Contact	Function - Accessory	Description
3 — 4 GND-OIMP	NO OUTER SIDE OPENING	Contact for connection of external detection radar. The closure of the contact activates an opening operation. NB: this command is only active with the COM400MKB-MHB function selector switch.
3 — 5 GND-O/C	NO STEP-BY-STEP	The closure of the contact activates an opening operation. The door stays open until a new command is given. If the door does not receive any command, it closes automatically after 15 minutes of inactivity. Automatic closing cannot be adjusted using the HOT trimmer; it is factory-set. The automatic closing time can be modified from 15 min to endless (∞), by altering the pre-configured parameters as explained in chapter 14. The opening/closing command only works in TWO-WAY mode. Modify the operating mode to CLOSED door or ONE-WAY opening, altering the pre-configured parameters as explained in chapter 14.
3 — 6 GND-KEY	NO KEY OPENING	The closure of the contact activates an opening operation. This command is always active, even when the COM400MHB/MKB function selector switch or ON-OFF-HOLD OPEN switch is installed. The automatic closure time is set to 5 s when the door is open regardless of HOT trimmer adjustment. Can be used for opening from night/CLOSED mode.

Contact		Function - Accessory	Description
3 — 7 GND-KILL	NO	EMERGENCY CLOSURE (FIRE BARRIERS)	<p>The closure of the contact activates an emergency closure operation. This command is active in every situation, and has priority over every other command.</p> <p>When the contact has reopened (with JUMPER J=ON), the door resumes operating as set by the selector.</p> <p> <b>WARNING:</b> if an EMERGENCY CLOSURE is activated, all the safety functions are ignored and the door closes. People or objects in the path of the door during the closing operation could suffer serious injury or damage.</p> <p>This function is generally used to cut off a specific area in the case of a fire.</p> <p>NB: this command can be combined with an emergency button.</p> <p>The output contact can be changed from NO to NC by altering the pre-configured parameters, as explained in chapter 13.</p> <p>The operation of the block during the emergency closure can be selected from the pre-set parameters explained in chapter 13.</p> <p>A panic bar can be installed in combination with a magnetic block on the fire barrier. In the event of a fire alarm or a power supply failure, the panic bar keeps the closed door blocked. In the case of escape routes, the panic bar can be manually released.</p> <p>Configure the relay contact of the DAB905ESA card, choosing parameter 11, 12 or 13 as explained in chapter 13.</p>
3 — 7 GND-KILL	NO	"NURSE & BED" FUNCTION	<p>In installations with parallel doors, the "NURSE &amp; BED" function can be enabled by connecting a switch to contacts 3-7 on the SLAVE door control panel.</p> <p>With 3-7 closed, opening of the MASTER door is enabled (NURSE function). With 3-7 open, opening of both doors is enabled (BED function).</p>
3 — 7 GND-KILL	NO	INTERLOCKED DOORS	Applications with interlocked doors are possible. For the connections, see paragraph 21.1.
3 — 8 GND-JRST	NO	EMERGENCY OPENING	If JUMPER=ON, the panel makes an automatic reset after an emergency closure.
3 — 9 GND-UNL	NO	DOOR RELEASED SIGNAL	<p>Contact for door released signal.</p> <p>The closure of the contact pre-empt the opening operation when the electric lock / electric strike is fully released, within the time set by the OPD (max 3 s).</p>
3 — 10 GND-OFF	NO	DOOR CLOSED	Contact for connecting a closed door timer.

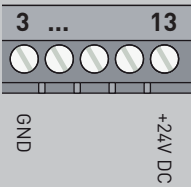
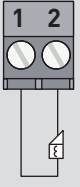
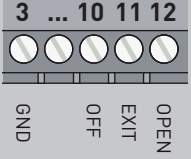
## 17.2 Outputs and accessories



Output	Description
	<p>Output for the power supply to the accessories 24V <math>\approx</math> 400 mA max. NB: the maximum absorption of 400 mA corresponds to the sum of all the accessories installed.</p>
	<p>Output for connecting an electric lock / electric strike. Select the type of electric lock / electric strike using DIP1. NOTE1: do not use electric locks / electric strikes with a reset feature. NOTE2: with DIP2 in OFF and no COM400 function selector switch (or the latter in two-way mode), output 1-2 is permanently powered so that the electric lock / electric strike can always open the door. If, on the other hand, you want to lock the door wing with the door closed, set the selector to one-way mode or make a jumper GND-EXIT (3-11). In this condition, output 1-2 is powered throughout the operation (from opening until complete closure); for this reason, locks with mechanical reset cannot be used. With DIP2 in ON, the behaviour will be the same except for the fact that output 1-2 will always be unpowered in two-way mode and throughout the open/close operation in one-way mode".</p>
	<p>Output for connecting the function selector switch. If the function selector switch is on OFF, the Push and Go function is disabled. If a function selector switch is installed, disconnect the ON/OFF/HOLD switch (if present).</p>
<p> For more information, refer to the COM400MKB-MHB selector manual.</p>	
<p><b>BATTERY</b></p> 	<p><b>BATTERY KIT</b> If no mains power supply is available, the battery kit will guarantee operation in "energy-saving" mode. If no mains power supply is available, the door only operates with the key switch connected to 3 GND -6 KEY. In "energy-saving" mode, the door can remain stationary for up to a week while waiting for the KEY command. By changing the pre-configured parameter group, you can set the battery kit to CONTINUITY mode. If no mains power supply is available, the door operates normally until the batteries are fully discharged. NB: for charging purposes, the battery kit must be connected to the control panel at all times. A new kit with fully-charged batteries can usually open and close a door consecutively in CONTINUITY mode. If you want to check the battery kit is working correctly, set DIP5=ON. In the event of a battery alarm, the DAB105CU control panel LED will flash twice. An acoustic/light alarm signal can be connected to terminals 6-7-8 on the DAB905ESA card.</p>

## 17.3. Adjustments



### Trimmer

Trimmer	Description
	<p>Adjustment of the opening delay time, from 0 s to 3 s. With the automation closed, a closure thrust is made simultaneously with the activation pulse prior to the opening operation. With DIP3=ON, the door release is active throughout the opening delay.</p>

### Dip-switches

DIP	Description	OFF 	ON 
DIP1	Power supply to the electric lock / electric strike.	12 V $\approx$ max 500 mA	24 V $\approx$ max 250 mA
DIP2	Type of electric lock / electric strike. DO NOT USE ELECTRIC LOCKS / ELECTRIC STRIKES WITH A RESET FEATURE.	Normal When it is powered, the door can be opened.	Anti-panic When it is unpowered, the door can be opened.
DIP3	Release	Disabled	Enabled during the time set by the OPD trimmer
DIP4	Electric lock / electric strike coupling	Disabled	Enabled When it approaches the closing stop, the door increases its force/speed to ensure correct closure on the electric lock / electric strike.
DIP5	Battery test	Disabled	Enabled

### Jumper

	Description	OFF 	ON 
	Emergency closure reset	Manual	Automatic

## 18. Extension unit DAB905ESA (optional)

There is a command extension card for managing motion sensors, alarm indications and door status.

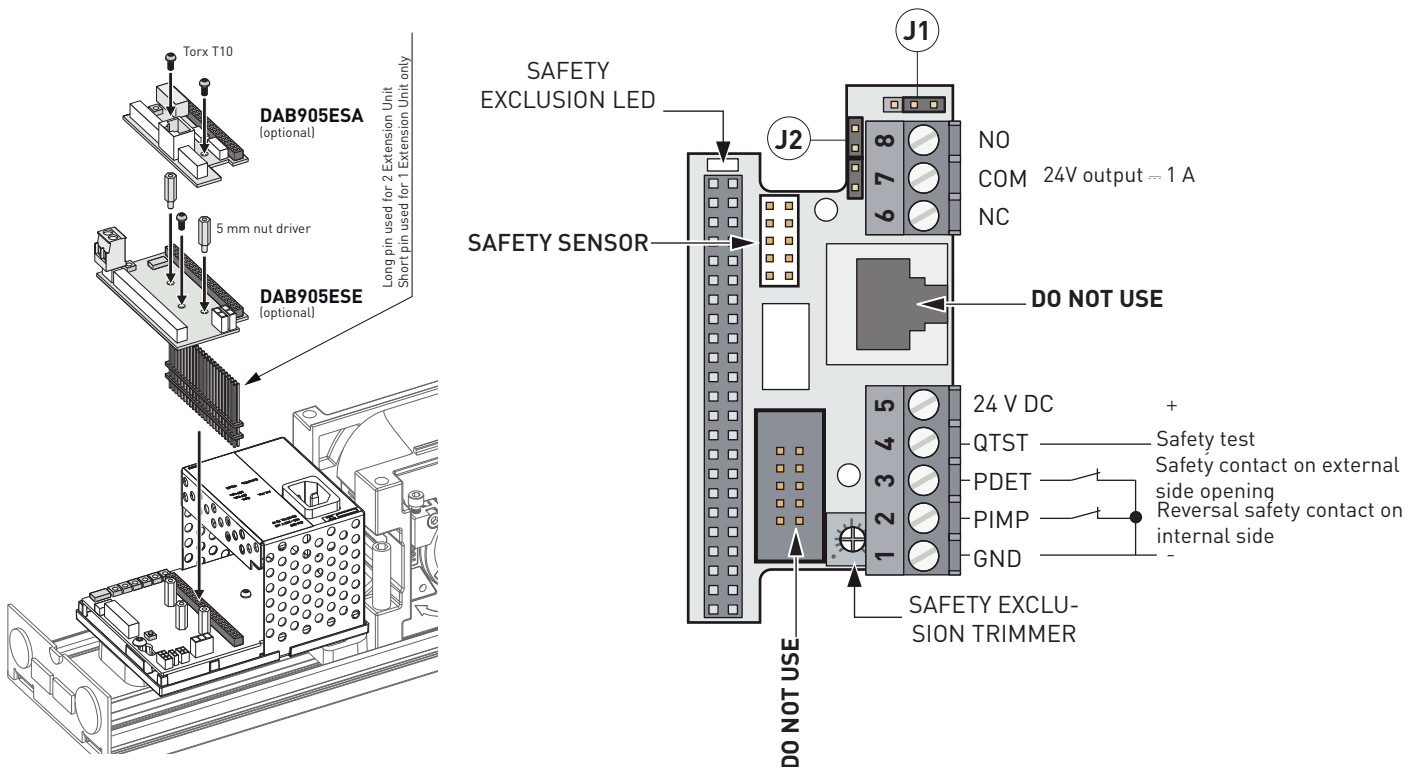

Fix the label to the terminal board, taking care to apply it in the correct direction (see the figure above).

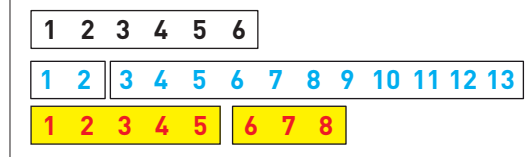



Remove the jumpers if a safety sensor is connected to terminals 1-2 and 1-3.

### 18.1 Commands

Contact	Function - Accessory	Description
1 — 2 GND-PIMP	NC REVERSAL SAFETY CONTACT INTERNAL SENSOR	The opening of the contact during the closure manoeuvre causes the movement to invert (reopening). NB: the opening of the contact of the motion sensor installed on double doors causes both doors to re-open. The sensor is not active in DOOR CLOSED mode (set via the function selector switch), or when the door is opened manually due to a power failure or emergency closure (KILL).
1 — 3 GND-PDET	NC OPENING SAFETY DEVICE EXTERNAL SENSOR	The opening of the contact causes the movement to stop during the opening phase. When the contact closes again, the automation resumes the interrupted opening operation. If the automation is closed, the opening of the contact prevents the opening operation. Adjust the safety exclusion trimmer so that the sensor does not detect the wall during the opening phase. During the opening phase, the safety sensor takes priority over the motion sensor. NB: the opening of the contact of the motion sensor installed on double doors causes both doors to stop, except in the case of double exit doors. Modify the operation of the double doors by changing the pre-configured parameters as explained in chapter 13. The sensor is not active in DOOR CLOSED mode (set via the function selector switch), or when the door is opened manually.
5 — 4 24V-QTST	SAFETY TEST	Connect the QTST terminal of the control panel to the corresponding test terminal on the safety device. A test will be carried out on the safety device before every operation.

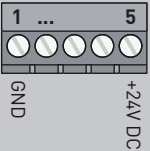
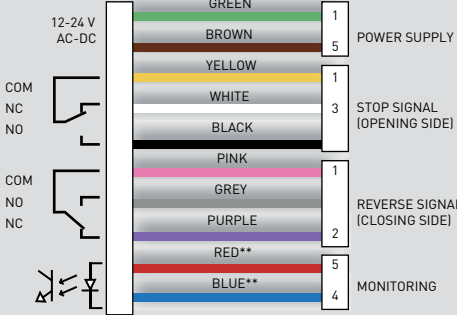
## 18.2 Outputs and accessories

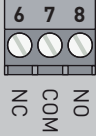







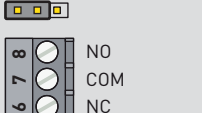

Output	Description
	<p><b>Output for the power supply to the accessories 24V = 400 mA max.</b></p> <p>NB: the maximum absorption of 400 mA corresponds to the sum of all the accessories installed.</p>
<p>SAFETY SENSOR</p> 	<p><b>Connect a self-checking safety sensor on the door wing.</b></p> <p>Connect the closing side sensor to terminals 1-2 (GND-PIMP).</p> <p>Connect the opening side sensor to terminals 1-3 (GND-PDET).</p> <p>NB: in the event of a safety sensor fault during opening, the door closes and stays closed. It can only be opened manually. In the event of a safety sensor fault during closing, the door stays open. By switching the function selector switch to DOOR CLOSED, the door can operate in Low Energy mode. It can only be opened manually.</p> <div style="background-color: #00AEEF; color: white; padding: 5px; margin-top: 10px;">  Remove jumpers 1-2 and 1-3.         </div> <div style="background-color: #00AEEF; color: white; padding: 5px; margin-top: 10px;">  For more information, refer to the REM sensor manual         </div>
	<p><b>Relay contact 24 V = 1A.</b></p> <p>The relay contact can be used as:</p> <ul style="list-style-type: none"> <li>- an output for the parallel connection of the EMERGENCY CLOSURE command on several fire barriers;</li> <li>- an output for connecting a block with a power supply other than 12/24V DC;</li> <li>- an output for connecting an error warning device (light or acoustic). The COM-NO contact opens and the control panel detects an error (flashing LED on the DAB105CU control panel). If there is no alarm/error, the COM-NO contact is closed.</li> </ul> <p>In the event of an error, refer to the "Alarms" paragraph (24.1).</p> <p>A device for indicating the open door can be connected.</p> <p>The open door position is adjusted by the opening safety exclusion trimmer.</p> <p>For a "door open" indication (from 45° to 90°), open the door with any opening command and adjust the trimmer until the LED on the DAB905ESA card lights up when the door is open (or is in the required opening position).</p>

## 18.3. Adjustments

### Trimmer

Trimmer	Description
	Adjustment of the opening safety exclusion, from 45° to 90°. During the door opening phase, this excludes the functioning of the safety device installed on the door wing, so that the wall is not detected. When the safety device is excluded, the LED lights up.

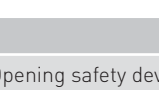
### Jumper

		Indication of external error / Output for parallel connection of Emergency Closure (KILL) / Block output
		Indication of door open
	OFF  ON 	Test on external sensor (GND-PDET)
	ON  OFF 	Test on internal sensor (GND-PIMP)
	ON  ON 	No test
	OFF  OFF 	Test on internal and external sensors (GND-PIMP / GND-PDET)

### Signals

	ON 	OFF 
LED	Opening safety device disabled	Opening safety device enabled

# 19. Example of an application

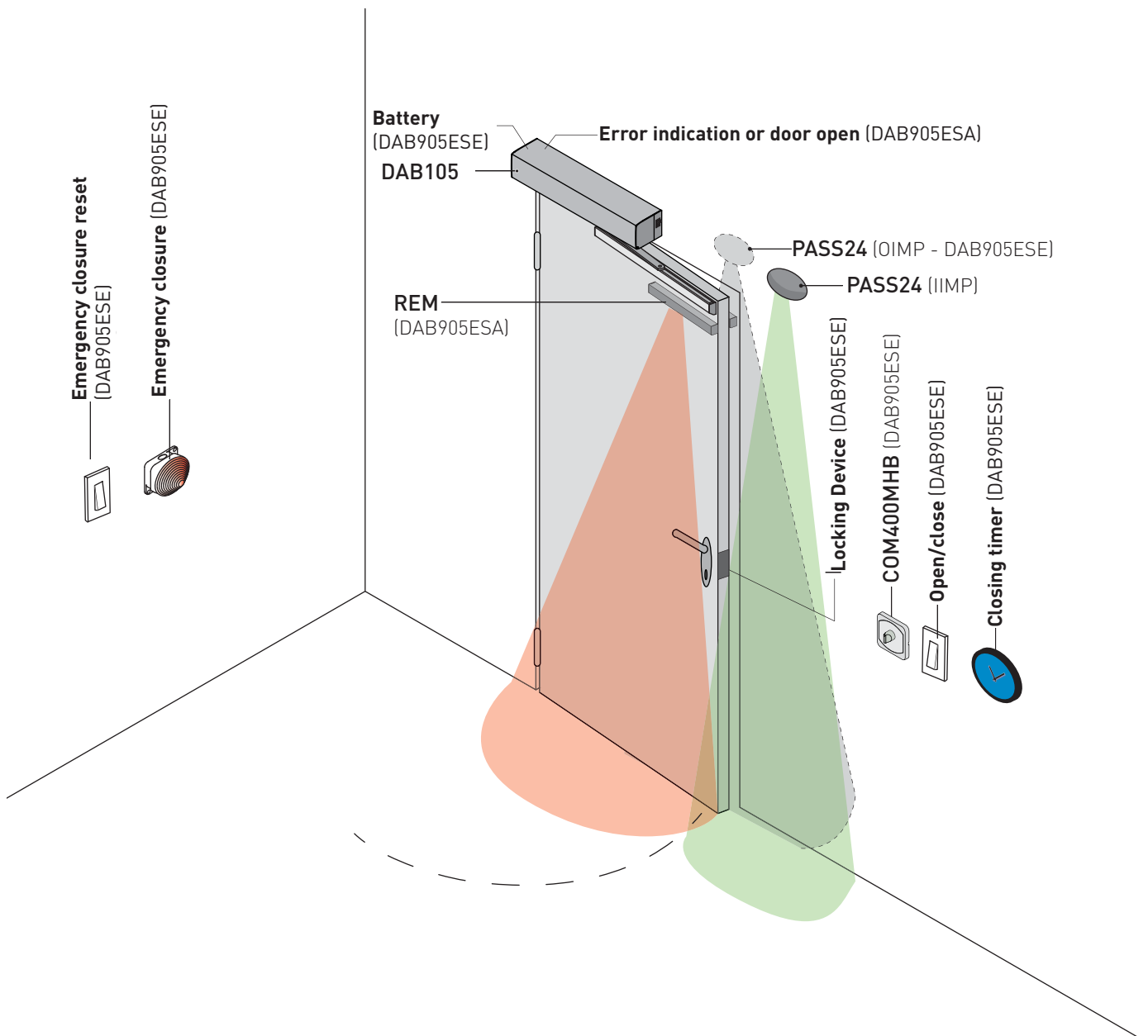

## 20. Parallel automations (DAB905SYN)

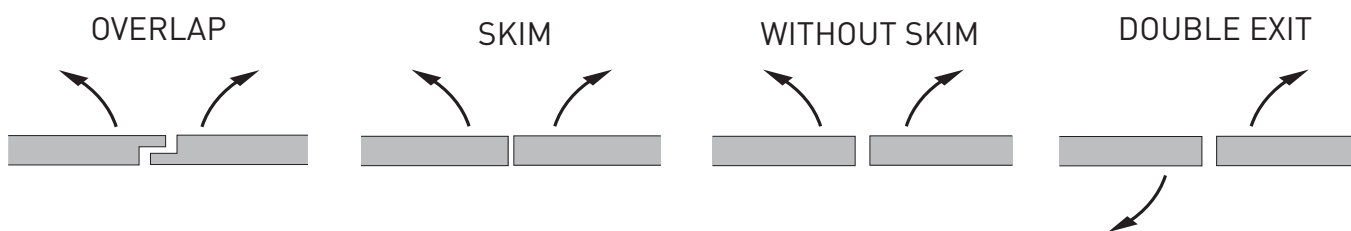

Connect the two automations to the plug on the control panel, using the synchronisation cable (DAB905SYN). Depending on the type of installation, cut the jumpers on the MASTER or SLAVE cable, as shown in the table:

**i** The MASTER automation is the one that opens first.

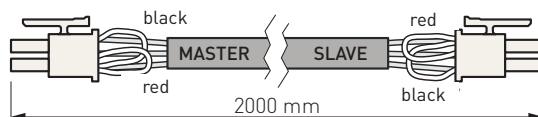

Operating mode		Type of application		Jumper to be cut	
Opening	Closure	Overlap	Skim	MASTER	SLAVE
Synchronous	Synchronous	NO	NO	/	/
Synchronous	Asynchronous	YES	NO	BLACK	/
Asynchronous	Asynchronous	YES	YES	/	RED
Double exit		/	/	BLACK	RED

### 20.1 Settings

Operating mode	Settings	
	MASTER	SLAVE
Program selection	X	
Opening time	X	
Closure time	X	
Closure time adjustment	X	
Closure / Opening attempt when the door is obstructed	X	
Enable / Disable PAG	X	
Level of servo-assistance	X	X (*)
Closure force	X	X (*)
Pulse of motion sensor or mat	X	
Selection of operating mode during battery functioning	X	
Lock/release signal tension	X	X
Block powered / Unpowered	X	X
Enable / Disable block release	X	X
Open door delay	X	X
Enable / Disable snap block	X	X

(\*) In double exit doors, these functions have to be set separately on the MASTER and SLAVE doors because the arm system and air pressure may differ.

**i**

- The electric locks / electric strikes must be connected to the MASTER and SLAVE control panels.
- The opening devices must be connected to either the MASTER or SLAVE control panel, or to both.
- The OPD motion sensor must be connected to the MASTER control panel except for double exit doors where each OPD motion sensor must be connected to the corresponding control panel
- The sensors fitted on the wing must always be connected to the corresponding control panel.

## 20.2 Example of installation of parallel doors (DAB905SYN)

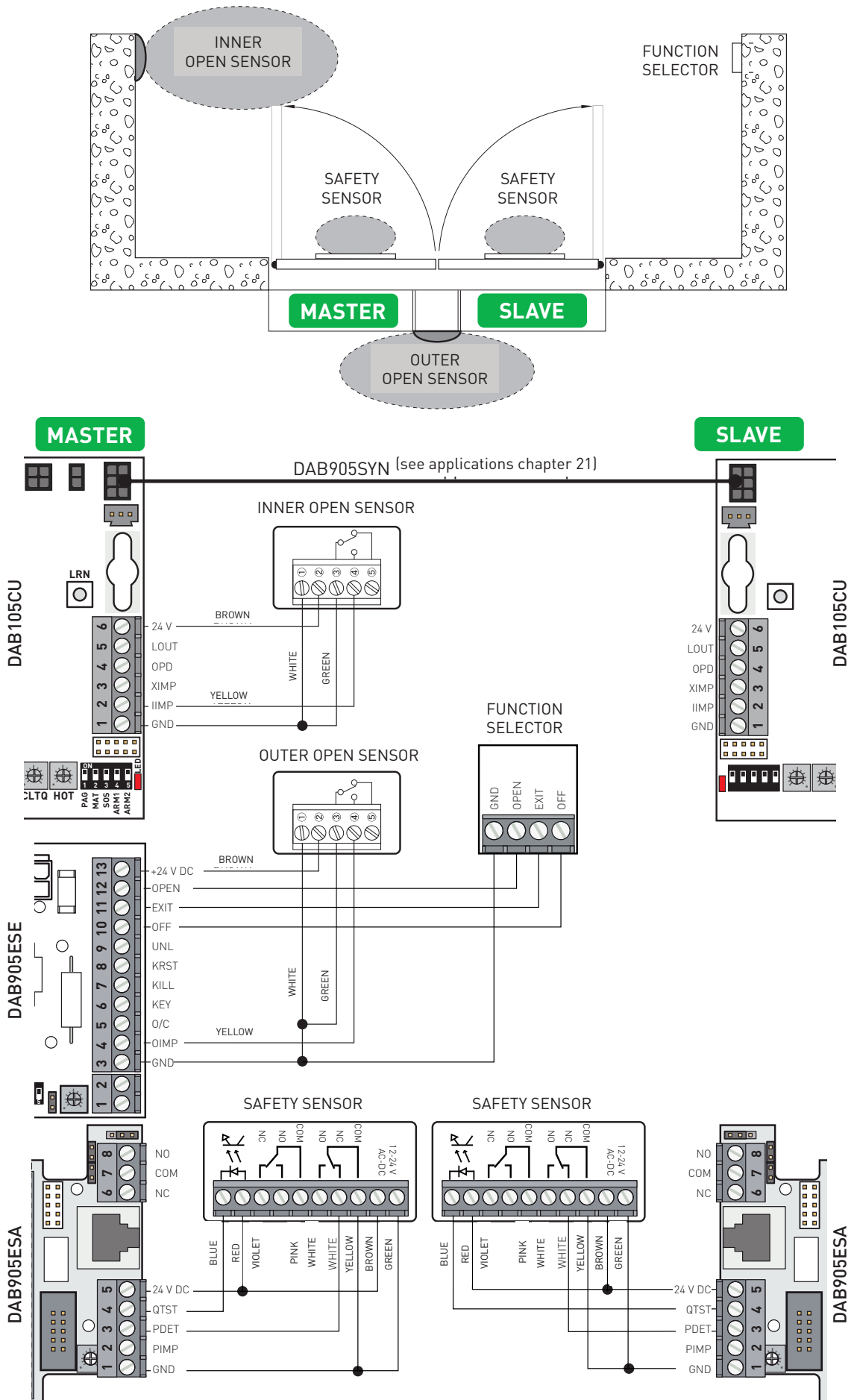

## 20.3 Interlocked automations (DAB905SYN)

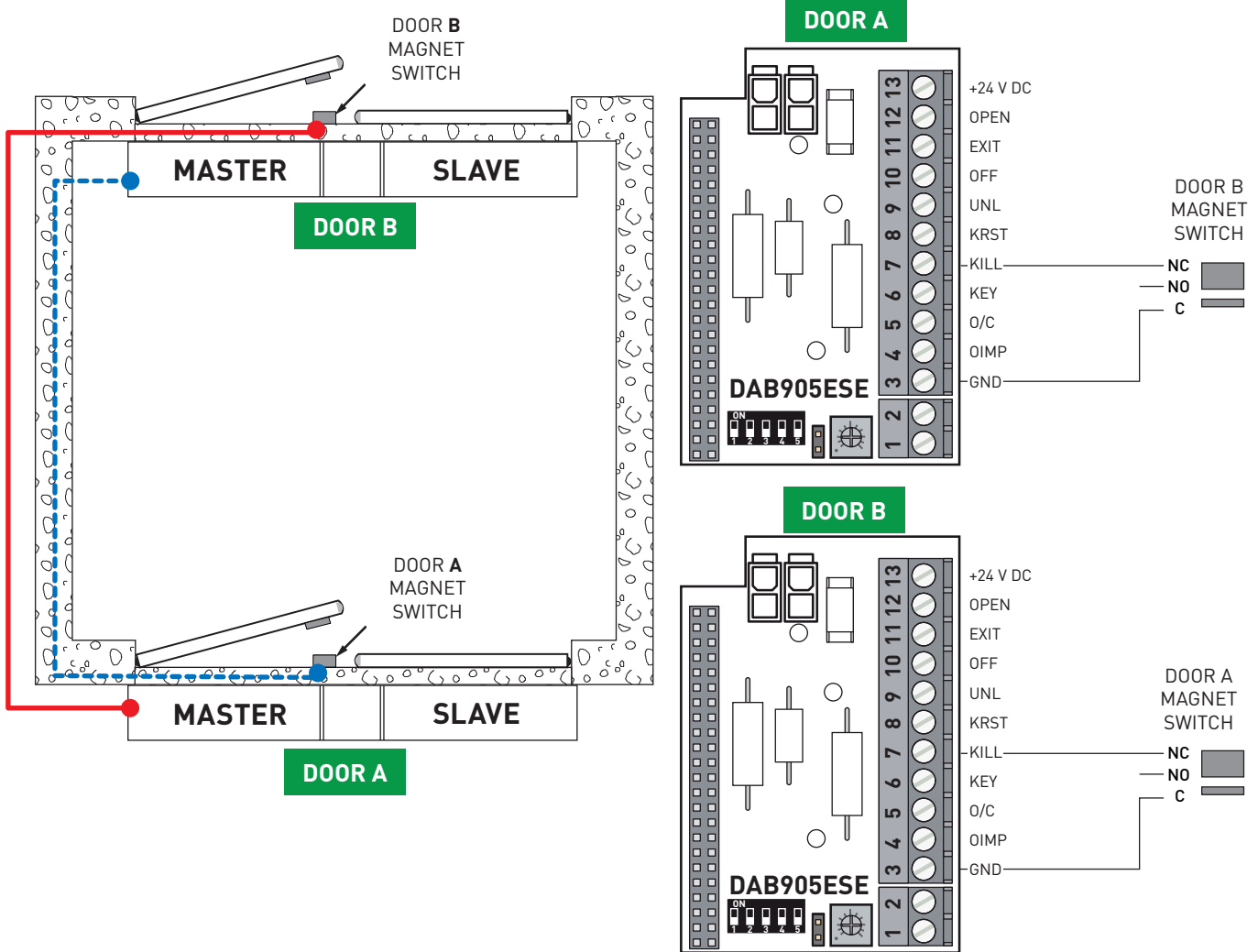

In applications for interlocked doors, a micro switch must be installed on the MASTER A automation in order to disable opening of the MASTER B automation and vice versa.

When both doors are closed, the 3-GND 7-KILL contact is open. The first automation that opens closes the contact and prevents the other automation from moving.

When the first automation has closed, the second automation can open by way of a second opening command.

NB: If a KILL command is given to the SLAVE automation, only the SLAVE door will stop.

NB: If single interlocked doors are installed, the same connections indicated above are used.

## 21. Electrical start-up



Before performing any type of operation, make sure that the automation is turned off and the batteries are disconnected.

The trimmers can only be adjusted with the automation idle.

1. Connect the motor and encoder cables to the DAB105CU control panel.
2. Turn on the power supply.
3. Press the LRN button for automatic self-learning.
4. In the case of parallel installations, the self-learning procedure must be carried out on the MASTER door first, then the SLAVE door. The self-learning procedures on the two doors can be carried out separately, before connecting the synchronisation cable. In the case of parallel doors with overlap, the MASTER door must stay open until the SLAVE door has completed its self-learning procedure.
5. Set the automatic closing time by means of the HOT trimmer.
6. Adjust the opening speed with the OPSP trimmer.
7. Adjust the closing speed with the CLSP trimmer.
8. Connect the accessories and check they are functioning.

## 22. Routine maintenance plan

Perform the following operations and checks every 6 months, according to the intensity of use of the automation.

Disconnect the 230V~ power supply and batteries (if present), and position the ON-OFF switch on OFF:

- Clean and lubricate the moving parts.
- Check the securing screws are firmly in place.
- Check all the electrical connections.
- Make sure the batteries are in good working order.

Restore the 230V~ power supply and batteries (if present), and position the ON-OFF switch on ON:

- Check the stability of the door, and make sure it moves smoothly.
- Check the condition of the pivots or hinges.
- Make sure all the command and safety devices are working properly.



NB: for spare parts, see the spares price list.

## 23. Troubleshooting

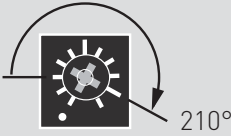
Problem	Possible cause	Solution / Explanation
The door does not open		
a) The motor does not start	The switch is set to OFF	Change the position of the switch
	There is no mains power supply	Check the mains power supply
	The command unit does not work	Connect the pulse inputs.
	The motion sensor has been activated	Remove any objects from the detection area
	Emergency closure activated	Deactivate the emergency closure
	SPT trimmer not set to 0°	Rotate the SPT trimmer to 0°
b) The motor starts	Mechanical lock blocked	Release the lock
	Obstacle	Remove any obstacles
	Door stop jammed	Select block release
	The arm system is coming loose	Rotate the SPT trimmer until the door stop is on the limit switch. Bring the door to its open position. Tighten the arm system. Rotate the SPT trimmer to 0°
The door does not close	The switch is set to HOLD	Change the position of the switch
	The motion sensor contact has been activated	Remove any objects from the detection area
	Obstacle	Remove any obstacles
The spring pre-tensioning on the automatic system is incorrect	The limit switches have been removed without the arm installed.	<ol style="list-style-type: none"> <li>1. Rotate the SPT trimmer until the end stop comes loose.</li> <li>2. Remove the end stop and the arm system.</li> <li>3. Disconnect the mains power supply.</li> <li>4. Disconnect the motor cable</li> <li>5. Replace the arm system and locate the non-pretensioning point by moving the door wing backwards and forwards.</li> <li>6. Loosen the arm.</li> <li>7. Reconnect the motor cable.</li> <li>8. Reconnect the mains power supply.</li> <li>9. Set the SPT trimmer to 210°.</li> </ol>  <ol style="list-style-type: none"> <li>10. Fix the end stop on the closure limit switch.</li> <li>11. Set the SPT trimmer to 0°.</li> </ol> <p>THE AUTOMATIC SYSTEM HAS RETURNED TO THE FACTORY SETTINGS</p>

## 24. Signs

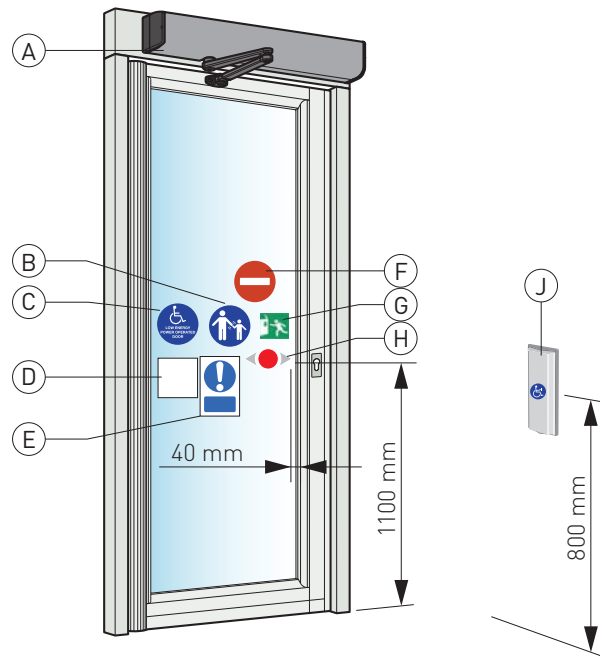

Make sure the signs are in good condition, and attach them.

Obligatory indicates that this sign is required by the European directives and equivalent national legislation outside the EEC.

Ref.		Description
A		Product label. Obligatory.
B		Supervision of children. Obligatory, if applicable. Attach to both sides of the door. Attach to doors used by children, the elderly and disabled (as shown by a risk analysis).
C		Automation suitable for the transit of disabled people. Recommended, if applicable. Attach to both sides of the door.
D		Automatic door. Obligatory in the UK only.
E		Do not block the passageway. Obligatory in the UK only.
F		No access. Indicates one-way transit. Obligatory in the UK and USA only, if applicable.
G		Emergency break-out. Obligatory if approved for escape routes.
H		Door label. Obligatory, if applicable. Warns of the presence of glass door wings. Attach to all mobile glass door wings.
J		The automation can be activated by disabled people. Recommended, if applicable.

---

**ENTRE//MATIC**



**Entrematic Group AB**  
Lodjursgatan 10  
SE-261 44, Landskrona  
Sweden  
[www.entrematic.com](http://www.entrematic.com)

