

FMT15101E, FMT15102E, FMT15104E, FMT15108E (Enclosed version)

FMT15101, FMT15102, FMT15104, FMT15108 (No Case version)

1, 2, 4, 8-Channel 151MHz Transmitter

Features

- Long range – up to 5km.
- 100mW Transmitter with current consumption of 85mA
- Not affected by Natural or man-made electrical interference
- Specially programmed micro-controller
- Simultaneous channel transmission is possible; i.e. more than one channel can be activated at a time.



Application

- Pump Control
- Long distance panic button
- On/Off applications in agricultural devices
- Security alarm
- Basic Telemetry eg. Water level indication

Description

The FMT151... has a transmission power of 100mW with a current consumption of only 85mA. It gives a controlled range of up to 5km. The controlled operation can be any electronic or electrical operated device when used with the FMR151... series of receivers

The channels are activated via screw type terminals onto which the user can connect reed switches, toggle switches, push buttons or any form of normally open (NO) contact.

The transmitter uses a frequency of 151MHz and a modulation type of Narrow Band Width FM which makes it suitable for industrial applications where you would have a high level of electrical interference. This transmitter is not affected by man made or electrical interference. This makes FMT151... an ideal choice for use in heavy industrial environment.

Each transmitter button is individually transmitted to the receiver making it possible to do simultaneous channel transmission. This means that up to 8 different functions can be done at the same time. Each button can operate any FMR151... series receivers making it possible to transmit each button to different single channel receivers or to multi channel receivers

The transmitter uses a specially programmed micro-controller which ensures the highest reliability, low standby current consumption (10uA) and greater flexibility. The greater flexibility allows customers to contact Elsema and request custom written software for special functions.

External supply connection and SO239 antenna socket is provided with the transmitter.

Compatible Products











Receivers:

- FMR15101 1-Channel Receiver with Relay Output
- FMR15101240 1-Channel Receiver with 240VAC Supply and with Relay Output
- FMR15102 2-Channel Receiver with Relay Output
- FMR15102240 2-Channel, Receiver with 240VAC Supply and with 2-Relay Outputs
- FMR15104 4-Channel Receiver with 4-Relay Outputs
- FMR15104240 4-Channel, Receiver with 240VAC Supply and with 4-Relay Outputs
- FMR15108 8-Channel Receiver with 8 Open Collector Outputs
- FMR1510812R 8-Channel Receiver with 12VAC or DC Supply and with 8-Relay Outputs
- FMR1510824R 8-Channel Receiver with 24VAC or DC Supply and with 8-Relay Outputs





Antenna:

- ANT151M - 1m 151MHz Antenna

Products in the Range

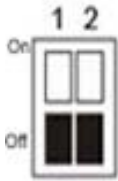
			
FMT15101E – 1 channel	FMT15102E – 2 channel	FMT15104E – 4 channel	FMT15108E – 8 channel
			
FMT15101 – 1 channel (No Case version)	FMT15102 – 2 channel (No Case version)	FMT15104 – 4 channel (No Case version)	FMT15108 – 8 channel (No Case version)
			
FMT15104H – 4 channel	FMT15108H – 8 channel		

Installation Instructions for FMT15101(E) & FMT15102(E)



	<p><i>Off Delay 2 – 62 seconds</i> Transmitter will transmit a 1.5 second transmission burst and then stop for the "off delay" time selected. The "off delay" time is user selectable between 2 to 62 seconds by adjusting trimpot on the transmitter board. If the inputs change during the "off delay" period the new code will be transmitted immediately. When the "off delay" time lapses, transmitter will transmit another burst. The transmitter will cycle (transmission and off delay) indefinitely, if at least one input is ON and supply is connected.</p>
	<p><i>Off Delay 1 – 10 minutes</i> Same as mode 1 except the "off delay" is user selectable between 1 to 10 minutes.</p>
	<p><i>Continuous Transmission*</i> Transmitter will transmit continuously, if at least one input is activated and supply is connected. A transmission limit of five minutes is used to comply with local radio regulations. To activate a receiver longer than 5 minutes, use a delay off feature in the receiver (FMR15101) and transmitter. The delay off feature in the receiver needs to be set <u>more</u> than the transmitter. This ensures that the transmitter keeps resetting the off delay in the receiver.</p>
	<p><i>1.5 – 10 seconds one burst transmission</i> Transmitter will transmit one burst and then go to standby or sleep mode. Adjusting the trimpot will vary the burst length. When the input is changed and supply is connected, transmitter will transmit one new burst of the new code.</p>
<p>Sleep mode (10 uA) is activated when all inputs are OFF; this applies to all four modes</p>	

(Grey illustrates the position of the DIP switches)

- Refer to the website for further details. <https://www.elsema.com/contitrans.htm>

The **transmitter mode for FMT15104** is user selectable by simply setting the **1-Way dip-switch** on the transmitter board.

Transmitter Modes (FMT15104)

	<p><i>Off Delay 2 – 62 seconds</i> Transmitter will transmit a 1.5 second transmission burst and then stop for the "off delay" time selected. The "off delay" time is user selectable between 2 to 62 seconds by adjusting trimpot on the transmitter board. If the inputs change during the "off delay" period the new code will be transmitted immediately. When the "off delay" time lapses, transmitter will transmit another burst. The transmitter will cycle (transmission and off delay) indefinitely, if at least one input is ON and supply is connected.</p>
	<p><i>Continuous Transmission</i> Transmitter will transmit continuously, if at least one code switch from the 12-Way code switch is ON and supply is connected. A transmission limit of five minutes is used to comply with local radio regulations. To activate a receiver longer than 5 minutes, use a delay off feature in the receiver (FMR15101) and transmitter. The delay off feature in the receiver needs to be set <u>more</u> than the transmitter. This ensures that the transmitter keeps resetting the off delay in the receiver.</p>

Transmitter mode for **FMT15108** is 5 min **Continuous transmission** only.

Coding Instructions

The 12 way dip switch on the transmitter sets the 12 bit unique code for the system. This has to be matched to that on the receiver.

Apart from the 12 way dip switch there will be a additional dip switch depending upon the transmitter type:

- A single channel Transmitter will have a 3 way dip switch
- 2-channel transmitter will have a 2 way dip switch
- 4-channel transmitter will have a 1 way dip switch
- 8-channel transmitter will not have any DIP switch (for channel selection) It only has a 12-way dipswitch for coding. The channels are determined by the 8 inputs.

This dip switch on the right side of the 12 way dip switch denotes the channel. These are denoted as below for the different transmitters.

FMT15101

With 3-way DIP switch and single input

FMT15102

With 2-way DIP switch and 2-inputs

SW1 3	SW1 4	SW15	Output
OFF	OFF	OFF	CH1
OFF	OFF	ON	CH2
OFF	ON	OFF	CH3
OFF	ON	ON	CH4
ON	OFF	OFF	CH5
ON	OFF	ON	CH6
ON	ON	OFF	CH7
ON	ON	ON	CH8

SW13	SW14	Output 1	Output 2
OFF	OFF	CH1	CH2
OFF	ON	CH3	CH4
ON	OFF	CH5	CH6
ON	ON	CH7	CH8

FMT15104

With 1-way DIP switch and 4-inputs

SW13	Output 1	Output 2	Output 3	Output 4
OFF	CH1	CH2	CH3	CH4
ON	CH5	CH6	CH7	CH8

Generally to use a 2-channel transmitter to 2-channel receiver match all the 14 DIP switch (12-way+2-way just on the right side of the 12-way).

To use a 2-channel transmitter to control 2 single channel receivers, match the 14 DIP switch positions and the receiver with the 15th DIP switch OFF is Ch1 and the 15th DIP switch ON is Ch2.

To use a 2 channel receiver with 2 single channel transmitters, first match the 14 DIP switches and then the transmitter with Sw15 OFF will activate the Ch1 on the receiver and the transmitter with Sw15 ON will activate the Ch2 on the receiver.

Operating Frequency

There are 7 selectable frequencies available. This is achieved by setting the 3-way dipswitch. The default setting is for 151.6MHz (All 3 dipswitches "ON"). Following is a table with the Dipswitch settings and the corresponding frequencies.



Frequency	1	2	3
151.600 MHz	On	On	On
152.375 MHz	Off	On	On
151.775 MHz	On	Off	On
151.400 MHz	Off	Off	On
151.175MHz	On	On	Off
151.025 MHz	Off	On	Off
150.900 MHz	On	Off	Off
150.825 MHz	Off	Off	Off

Technical Data

Power Supply	11 to 13.6 VDC (for constant RF-Output), screw type terminal. Absolute maximum 14VDC.	
Current Consumption	Nominal 85mA at 12VDC supply (Transmitting) Nominal 12mA on standby (10uA on sleep mode, all inputs off)	
Operating Frequency	151.6MHz (8 selectable frequencies. See table above)	
Operating Temperature Range	0 - 50°C	
Type of Emission	Narrow-band-width Frequency Modulation	
R.F. Output Power	100mW, into 50 ohms SO239 socket	
Baud Rate	40 to 4800bps.	
Digital Coding System	On-board 12-way Code Switch	
Antenna	SO239 socket is provided. Optimum performance use Elsema ANT151M antenna	
Dimension	90 X 56 X 15 mm (PCB Assembly)	140 X 60 X 34 mm (Enclosed).
Mounting Hole Size	4.00 mm or 5/32 " (PCB Assembly)	4.76 mm or 3/16"
Mounting Hole Spacing	Length 76 mm (3.00") Width 45 mm (1.77") (PCB Assembly)	Length 125 mm (4.92") Width 45 mm (1.77") (Enclosed).
Weight	85 grams (PCB Assembly)	225 grams (Enclosed).
Useable Operating Range	Up to 5000 meters, depending on installation and type of antenna used. Recommended Antenna is Elsema ANT151M	
Compatible Receivers	All Elsema type FMR-151... series	

Wiring Diagrams

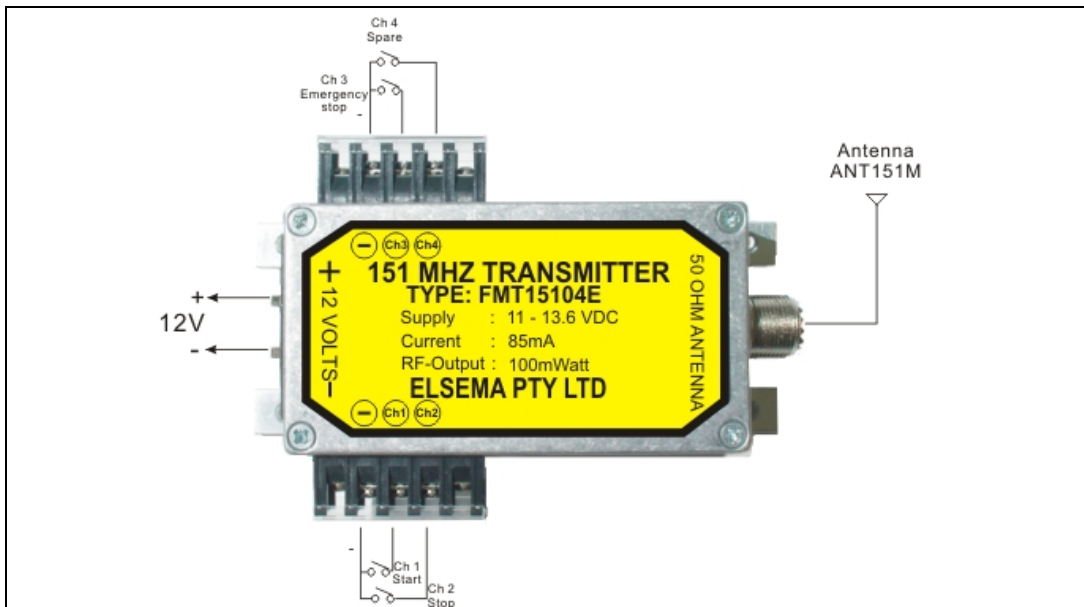
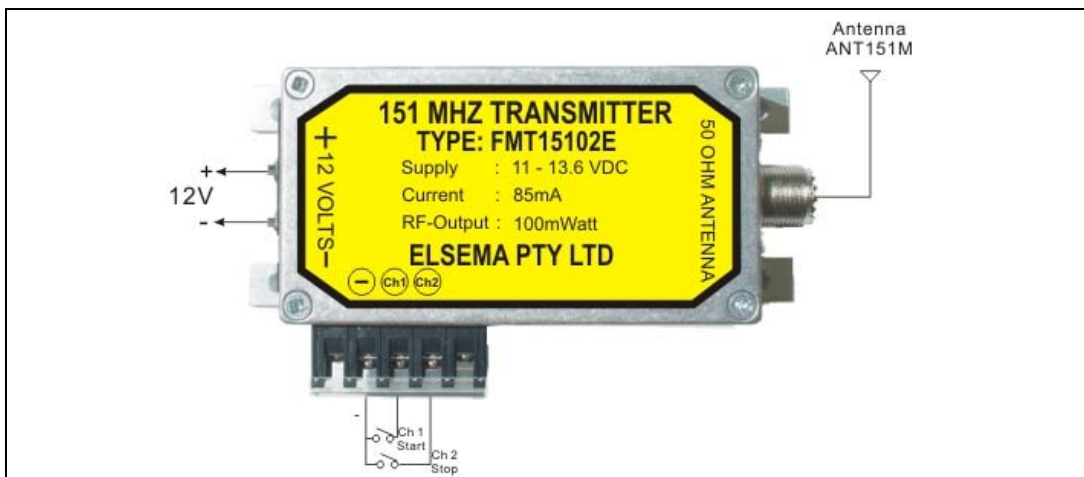
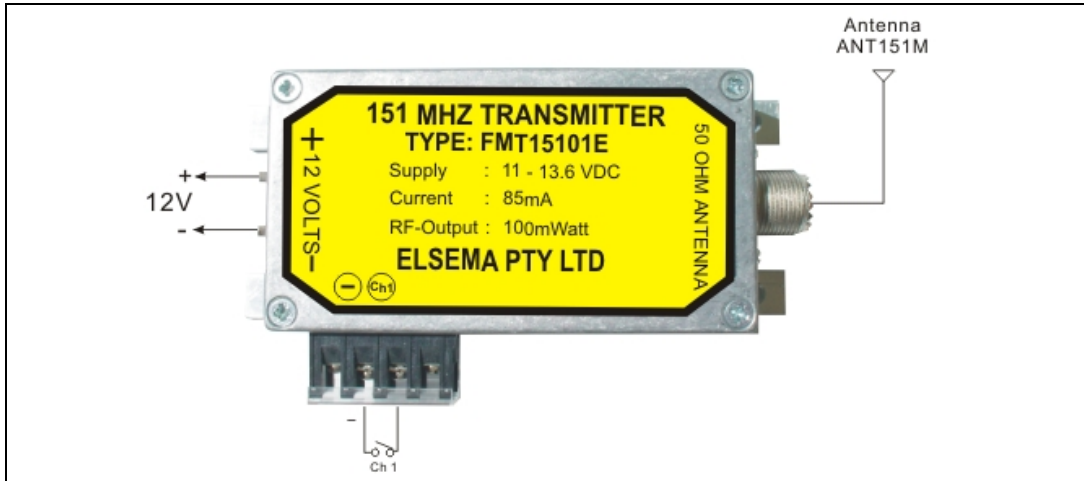

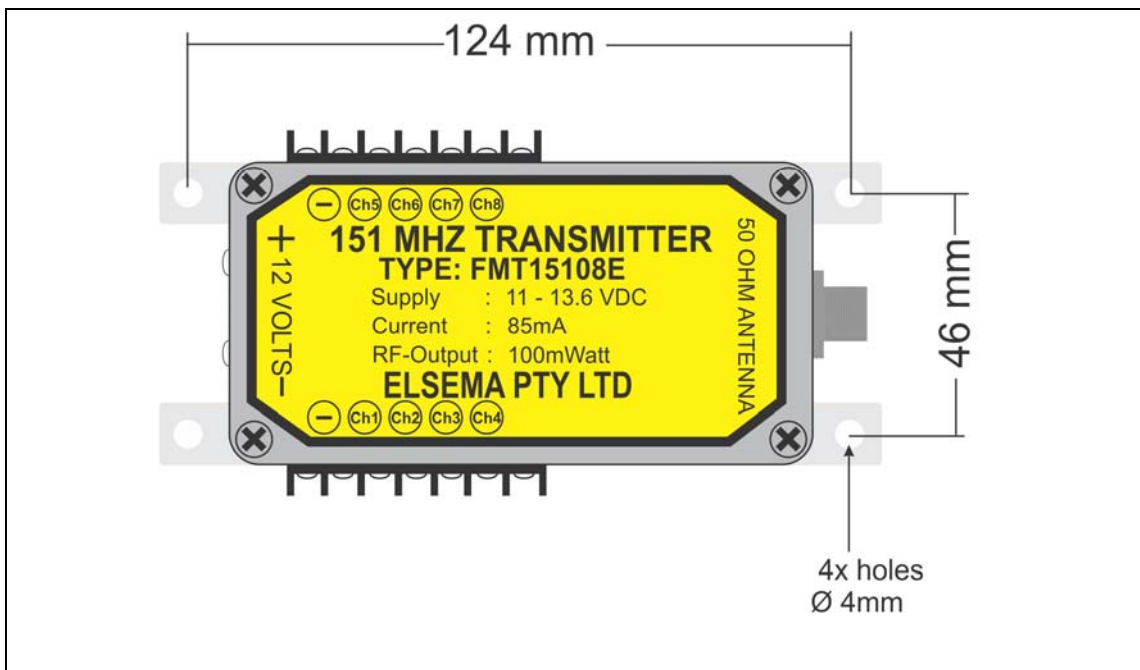
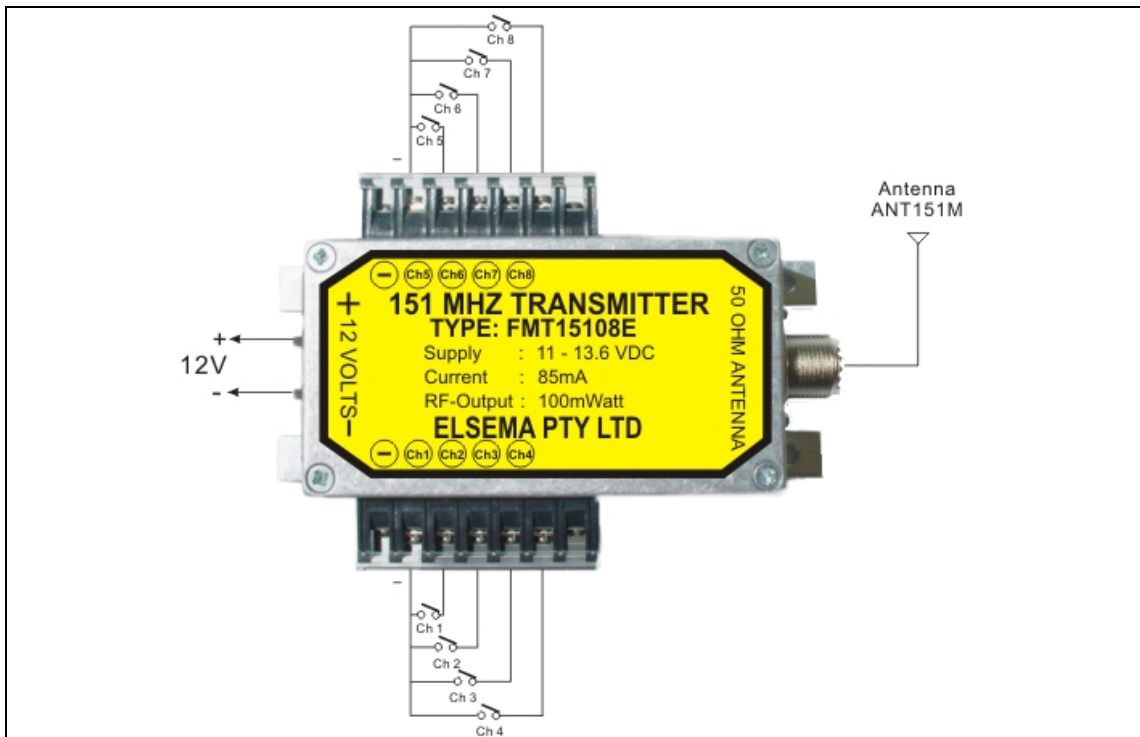

Manufactured by

Elsema Pty Ltd
 31 Tarlington Place, Smithfield
 NSW 2164
 Ph: 02 9609 4668
 Fax: 02 9725 2663
 Website: <http://www.elsema.com>

Distributed by

