

Electromechanical Bolts



We take the worry out of
protecting what's valuable to you.
Lockwood: *no worries*[®]

LOCKWOOD

ASSA ABLOY

5YEAR

**TRICARE
WARRANTY**

PADDE SERIES

www.lockweb.com.au

Contents



TB25
Drop Bolt
page 3



TB25KO
Drop Bolt
page 5



ES6000
Hook Lock
page 7



ES8000-S
V-Lock
page 9



ES8000
Glass Door Bracket
page 11



ES8200
Technilock
page 13

TB25 Drop Bolt



The Lockwood Padde Series TB25 range of drop bolts represent true engineering innovation, design excellence and the superior quality customers have come to expect and demand from Lockwood. Designed for use on swing-through, double action doors and ideal for applications where an electric strike is impractical.

Features

- High Security: bolt is deadlocked in the extended position
- Bolt position monitored
- Door position monitor with integrated magnet in the strike plate (no need to install a separate reed switch)
- Multiple orientation, drop bolts will work horizontally or vertically
- Power to Lock/Power to Open
- Continuously rated solenoid
- Tamper proof: lock cannot be defeated by slipping a metal object between lock and striker plate
- Intelligent electronics: these intelligent bolts will attempt to re-close the bolt 8 times, allowing time for swing through doors to settle in the closed position
- Thermal protection: in the event of solenoid overheat, a thermal fuse will operate eliminating any fire risk
- 5 Year Tricare Warranty (Padde Series)



Applications

- Misaligned doors
- Timer doors

Product Details

Voltage	12 to 24V
Current (Start)	1100mA @ 12V, 1000mA @ 24V
Current (Holding)	210mA @ 12V, 90mA @ 24V
Holding Force	1000kg
Locking Mode	Fail safe or Fail Secure (non field selectable)
Dimensions (Mortice)	164 x 22 mm
Bolt Length	12.7 x 16 mm
Face Plate Size	10 x 25 mm
Monitoring Contacts	Bolt and Door

Standards and Compliance

	CE Approved
	C-Tick Certified

TB25 Drop Bolt

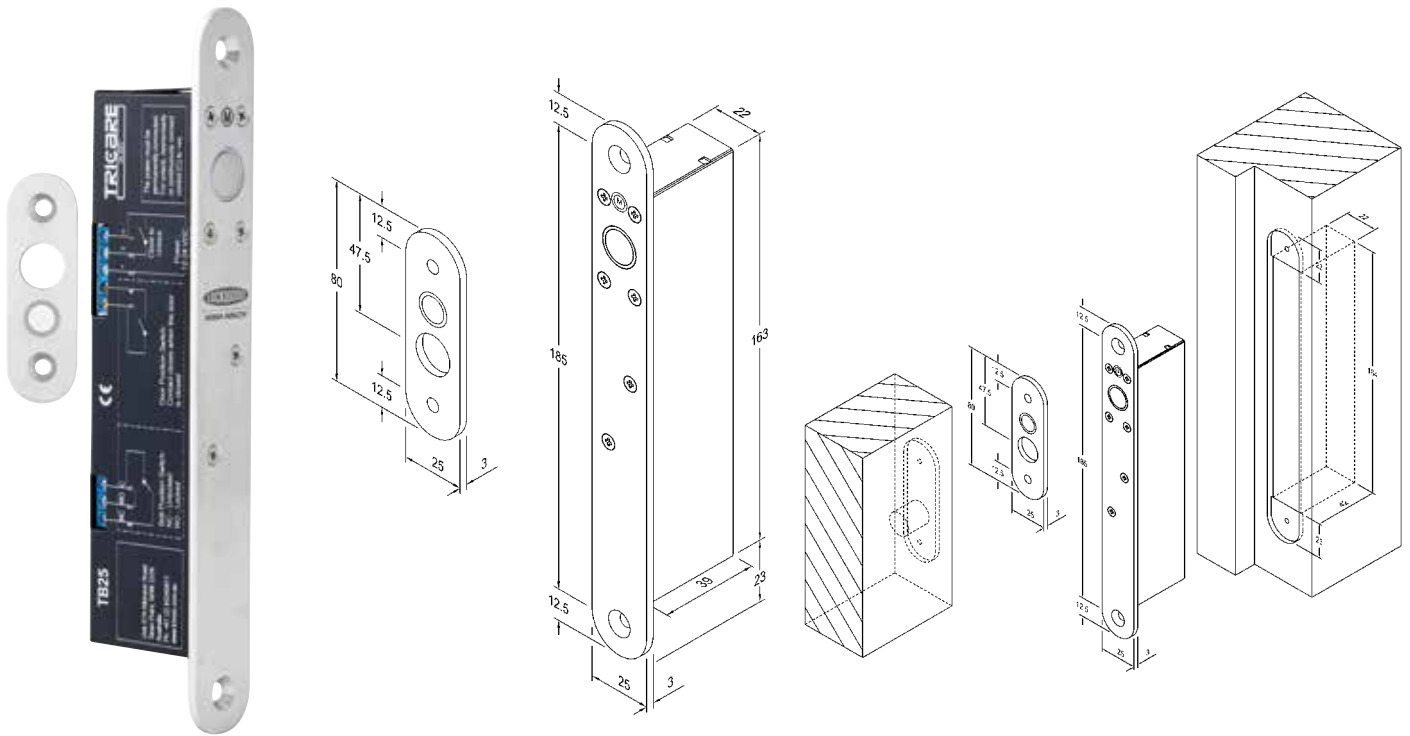

Ordering Information

Part Number	Product Description
TB25-1	TB25 D/Bolt 12-24Vdc Fail Safe Monitored
TB25-2	TB25 D/Bolt 12-24Vdc Fail Secure Monitored
Accessories	
228250-000	EB25 SS Short Strike Plate RH
228250-002	EB25 SS Long Strike Plate RH
228250-003	EB25 SS Housing
228250-004	EB25 SS Dress Plate
228250-005	EB25 L Bracket with Magnets
228250-006	EB25 L Bracket without Magnets

Specification Statement

The bolt must be able to operate in horizontal and vertical orientations. The position of the bolt must be monitored as well as have an integrated reed switch for door position monitoring. The electronic functions must include: 8 x lock and unlock attempts, 8 second unlock delay, automatic relock after 8 seconds, power reduction circuitry to limit the holding current and a one time thermal fuse cut-out in case of solenoid overheating. The face plate and strike plate must be finished in stainless steel.

TB25KO Drop Bolt



The Lockwood Padde Series TB25KO range of drop bolts represent true engineering innovation, design excellence and the superior quality customers have come to expect and demand from Lockwood. Designed for use on swing-through double action doors and are ideal for applications where an electric strike is impractical. The TB25KO offer a unique mechanical override with an integrated Euro Profile Cylinder.

Features

- High security: bolt is deadlocked in the extended position
- Mechanical key override in the event of power failure (Euro Profile Cylinder)
- Bolt position monitored
- Door position monitor with integrated magnet in the strike plate (no need to install a separate reed switch)
- Multiple orientation: drop bolts will work horizontally or vertically
- Power to Lock/Power to Open
- Continuously rated solenoid
- Tamper proof: lock cannot be defeated by slipping a metal object between lock and striker plate
- Thermal protection: in the event of solenoid overheat, a thermal fuse will operate eliminating any fire risk
- 5 Year Tricare Warranty (Padde Series)



Applications

- Misaligned doors
- Timer doors

Product Details

Voltage	12 or 24Vdc
Current (Start)	1100mA @ 12V, 1000mA @ 24V
Current (Holding)	210mA @ 12V, 90mA @ 24V
Holding Force	1000kg
Locking Mode	Fail safe or Fail Secure (non field selectable)
Dimensions (Mortice)	228 x 22 mm
Bolt Length	12.7 x 16 mm
Face Plate Size	280 x 25 mm
Monitoring Contacts	Bolt, door and key

Standards and Compliance

	CE Approved
	C-Tick Certified

TB25KO Drop Bolt

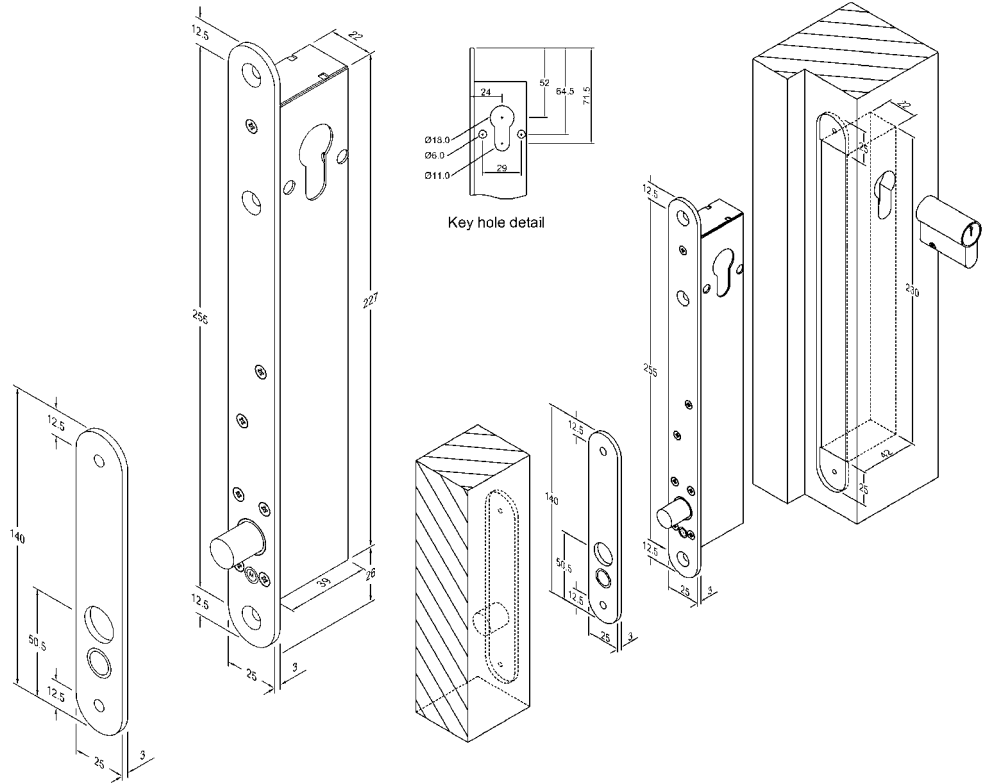

Ordering Information

Part Number	Product Description
TB25KO-1	TB25 K/O D/Bolt 12-24Vdc Fail Safe Monitored
TB25KO-2	TB25 K/O D/Bolt 12-24Vdc Fail Secure Monitored
Accessories	
228250-502	EB25KO SS Housing for Bolt

Specification Statement

The bolt must be able to operate in horizontal and vertical orientations. The position of the bolt must be monitored as well as have an integrated reed switch for door position monitoring. The electronic functions must include: 8 x lock and unlock attempts, 8 second unlock delay, automatic relock after 8 seconds, power reduction circuitry to limit the holding current and a one time thermal fuse cut-out in case of solenoid overheating. The face plate and strike plate must be finished in stainless steel.

ES6000® Hook Lock



Lockwood Padde Series ES6000 Hook Lock is suitable for swinging doors, sliding doors and is easily attached to wood or steel door frames. ES6000 is heavy duty designed with its high pre-load (side load) capability of up to 300 kg, high holding force of up to 700 kg and up to 4hr fire rating. Both Power to Open and Power to Lock models are available.

The ES6000 is available in both recess and surface mounted versions.

The ES6000 recess mounted version is completed with an elegant satin stainless steel face plate. The surface mounted version is completed with a cast aluminium cover that can be supplied in a variety of colours to match existing door frames.

ES6000 can be mounted vertically and horizontally, with self-latching ability without power for fire applications.

Features

- Power to Open or Power to Lock versions available
- Side load (pre-load) capable: operates freely with up to 300 kg of side pressure
- Self latching: will self latch without power for fire applications

- 680 kg holding force
- Robust construction: stainless steel components used
- Low profile: will protrude only 40 mm into door headroom
- Multi voltage: automatic selection 12 to 30Vdc with back EMF protection and reverse polarity protection
- Multi orientation: can be mounted vertically or horizontally
- Low current consumption 12VDC-250mA after 1 sec. (initial current 830mA) 24VDC-140mA after 1 sec. (initial current 530mA)
- Monitored: locked and unlocked
- Tested to the 300 kg pre-load capability
- 5 Year Tricare Warranty (Padde Series)

Applications

- Heavy duty applications
- Sliding and swing door applications
- High air pressure environments (high pre-load rating)

Product Details

Voltage	Supply Voltage 12-30Vdc Ground (OV)
Current	12Vdc-250 mA after 1 sec. (initial current 830mA) 24Vdc-140 mA after 1 sec. (initial current 530mA)
Monitoring	Door Locked (Solenoid) - Door Closed (Latch)
Strength	1500 lbs. (680 kg) static strength rating 70 foot-lbs. dynamic strength rating
Endurance	250,000 cycles endurance testing Internal testing achieved: 2,000,000 cycles of operation
Pre-Load	660lbs (300kg) pre-load capability
Environment	Operational temperature range: -20°C to +60°C
Lock Body	Cast Aluminium Construction
Lock Bolt	Solid Stainless Steel

Standards and Compliance



Successfully fire rated up to 2 hours on fire door assemblies in accordance with AS1905.1. 2005 (Part 1: Fire resistant door sets)



Approved to UL1034 (highest level)



C-Tick Certified



PADDE SERIES

ES6000 Hook Lock

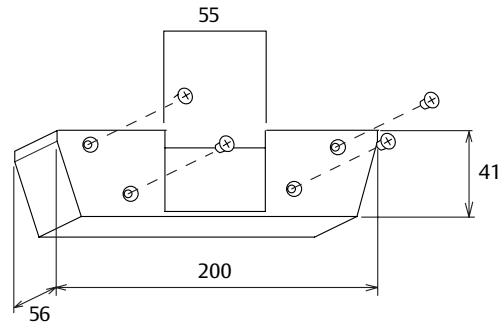
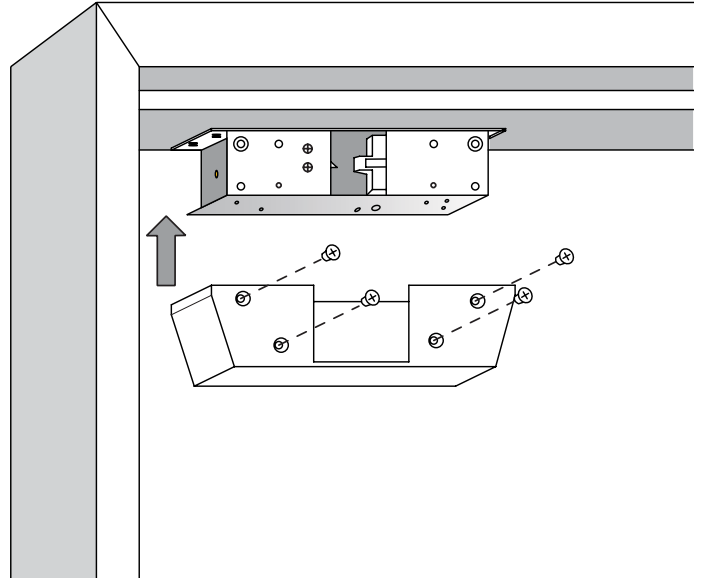

Ordering Information

Part Number	Product Description
ES6000M-1	ES6000 Hook Lock Mortice 12/24Vdc Fail Safe Monitored
ES6000S-1	ES6000 Hook Lock Surface 12/24Vdc Fail Safe Monitored
ES6000M-2	ES6000 Hook Lock Mortice 12/24Vdc Fail Secure Monitored
ES6000S-2	ES6000 Hook Lock Surface 12/24Vdc Fail Secure Monitored

Accessories

206000-010	Spare Cover for Hook Lock, Silver
------------	-----------------------------------

Specification Statement

This lock must be able to operate with up to 300 kg of preload pressure, with a holding force of 700 kg. The lock must be multi voltage selection 12 - 30 Volts with back EMF protection for reverse polarity. Lock can be mounted both horizontally or vertically. The lock needs to be subjected to vigorous testing and achieve a minimum of 2,000,000 cycles.

ES8000-S V-Lock



The Lockwood Padde Series world famous and original V-Lock has been completely re-engineered to provide superior performance and reliability.

The ES8000-S now incorporates a new motor and 1:19 ratio gearbox providing up to 65% additional preload capability and a higher locking force up to 10Kg.

The electronic circuitry has also been completely upgraded to intelligently detect the locked state with “smart” retry function & uses on average 25% less peak current draw.

Aside from some minor cosmetic changes, the lock body and overall footprint remains unchanged and is a direct retrofit for the original V-Lock.

Features

- Side load - Pre-load Capable Lock will unlock with up to 25kg of side pressure, when wired in 3 wire mode
- Door misalignment of up to 3.5mm +/- (total of 7mm)
- Power to Lock (Fail Safe) / Power to Open (Fail Secure) field configurable
- High Torque Motorised locking and unlocking (3 wire mode)

- High Speed Operation. Unlocks in less than 1 second
- Intelligent smart retry locking function
- Surface Mount Accessory Kit. Ideal for 180° swing through glass door applications
- Multiple applications – For Interior Doors the lock can be mounted vertically or horizontally (Note: for exterior doors due to possible water ingress the ES8000 must be mounted horizontally)
- 5 Year Tricare Warranty (Padde Series)

Applications

- Misaligned doors
- Timber doors
- Glass doors

Functions

The ES8000-S has a high torque motorised bolt that moves from the vertical position to the horizontal state when locked. The bolt moves into the V shaped strike plate & allows for door misalignment of up to 7mm. The high torque motorised bolt can be concealed from view or surface mounted and has the world’s first fail-safe motor locking mechanism.

Product Details

Voltage	12 to 24Vdc, Voltage Tolerance 12V(+15% - 0%) 24V(+/- 15%)
Peak Current	1000mA*
Idle Current	19mA
Monitoring	COM, NO, NC Voltage free changeover contacts rated at 30 vdc/100mA
Unlocking Time	1 sec
Locking Time	3 sec
Security Passed	S3 (AS4145.2-1993)
Strength Maximum	1000kg (with supported strike plate and bracket)
Unlocking Preload	Side Load rated: Motorised Unlocking - 25kg max at bolt
Locking Force	Fail Safe Unlocking - 10kg max at bolt
Endurance	300,000 operations
Environment	Operational temperature range -20°C to +60°C
Locking Body	Stainless Steel Lock Body and Faceplate
Bolt	11mm diameter, 20.5mm projection

* Peak current is reduced but a 1000mA power supply is still required for 12v installations.

Standards and Compliance



Successfully fire rated up to 4 hours on fire door assemblies in accordance with AS1905.1. 2005 (Part 1: Fire Resistant Doorsets).



C-Tick Certified



PADDE SERIES

ES8000-S V-Lock

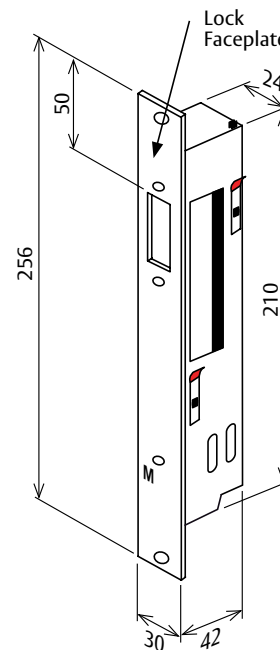
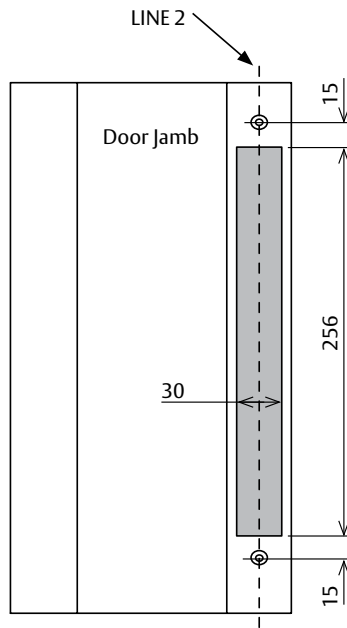

Wiring below shows lock in locked position

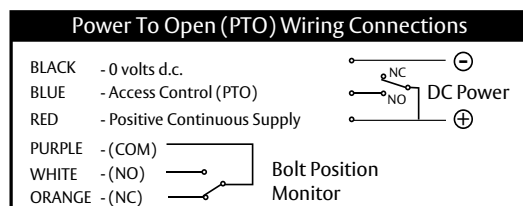
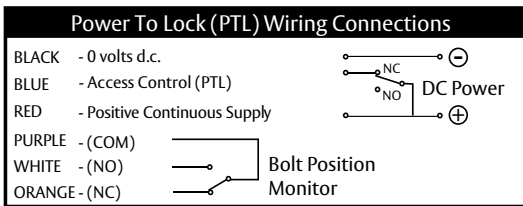

Ordering Information

Part Number	Product Description
ES8000-1	ES8000 D/Bolt 12-24Vdc Fail Safe Monitored
ES8000-2	ES8000 D/Bolt 12-24Vdc Fail Secure Monitored
ES8000HS-1	ES8000 D/Bolt High Sec 12-24Vdc Fail Safe Monitored
ES8000HS-2	ES8000 D/Bolt High Sec 12-24Vdc Fail Secure Monitored
Accessories	
208000-000	ES8000 V-Lock Glass Door Housing (including dress plate and fixing tape)
208000-003	ES8000 V-Lock Strike Plate with Magnet (spare part)

Specification Statement

The lock must be a high torque motorised bolt with pre-load tolerance. The strike plate must be shaped in a V format to accommodate for misaligned doors. Lock will unlock with up to 25kg of side pressure and will be powered with 12-24v and draw no more than 1000mA. The lock must be configured for Power to Lock (fail safe) or Power to Open (fail secure). The lock must be triggered with a magnet positioned in strike plate and be monitored for locked unlocked and door position.

ES8000 Glass Door Bracket



The ES8000 Glass Door Bracket is the ideal solution when it comes to 180° swing through doors or double action glass doors. Until now we had to rely on other products for these applications. This bracket works in conjunction with the ES8000 and is not limited to glass thickness. As we know there are many factors that cause side load/pressure, the ES8000 resolves this problem and still offers a secure and reliable locking solution that is aesthetically appealing for glass doors.

The ES8000 Glass Door Bracket is fixed to the glass by means of 3M self adhesive tape. This type of fixing gives a great aesthetic appearance as well as easy installation.

Note: Two brackets are required if there is a glass header, also it's important to note that the bracket/s should always be installed at the secure side of the door.

Notes On The 3M Self Adhesive Tape

As per the 3M published data and given the surface area of the V-Lock glass door housing (around 20 sq. in.), this equates to around 900kg holding force under laboratory conditions. The actual shatter point of glass varies from door to door depending on the condition of the glass (scratches, chips etc). But any attempt to leverage a glass door beyond 500kg will more than likely shatter it.

Features

- Self adhesive holding force 900kg
- Includes dress plate for opposite side of door
- 5 Year Tricare Warranty (Padde Series)

Applications

- Frameless glass doors with solid header frame
- Frameless glass doors with frameless glass header (two brackets required)
- 90° and 180° single and double swing glass doors
- Other surface applications for timber doors.

ES8000 Glass Door Bracket

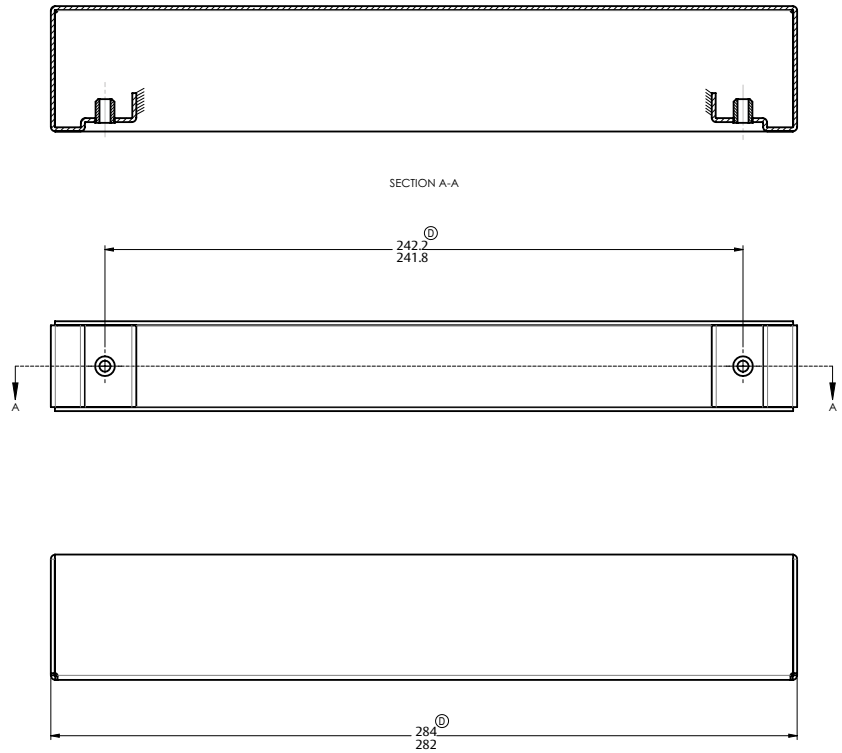

Ordering Information

Part Number	Product Description
208000-000	ES8000 V-Lock Glass Door Housing (incl Dress Plate and 3M fixing tape)

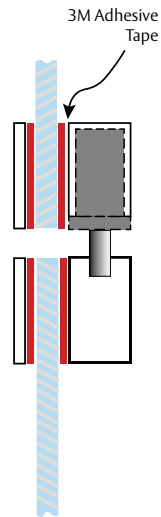

ES8200 Technilock®



Lockwood Padde Series ES8200 Technilock is a high security locking solution with comprehensive resistance against all types of attack and manipulation. Originally designed and developed for custodial purposes, the Technilock is in use today in government institutions, banks, embassies and jewellers.

ES8200 is available in 30mm and 60mm backset, in both Power to Lock or Power to Open configuration. Key override monitoring version is also available.

Features

- Side load (pre-load) capable – bolt will release with up to 70kg of side pressure – ideal for use on doors with seals or doors that are subjected to high wind load or air-conditioning pressures
- Extreme holding force – will withstand more than 2500kgs, the test rig manufactured to test the bolt broke at 2500kg so the bolt will withstand more than this

- Power to Lock and Power to Open (must be specified) versions available on request. The bolt is not interchangeable in the field and configuration must be specified when ordering
- High speed operation – locks in less than 1 second
- Multiple orientations – can be mounted horizontally or vertically
- Comprehensive monitoring – bolt locked, door closed, optional key-override monitoring
- 5 Year Tricare Warranty (Padde Series)



Applications

- High security locking
- Government applications
- Custodial applications
- Banking and security applications

Product Details

Voltage	3 wire control - 24Vdc regulated supply only
Current	Start current 4.5 Amp (24Vdc) for ½ second Holding current 500mA (24Vdc)
Monitoring	Bolt position 25mA (30Vdc) NC - Door position 25mA (30Vdc) NC
Holding Force	In excess of 2500kg holding force
Pre Load	Will open with 70kg of side pressure (pre-load)
Bolt Throw	Dead Bolt throw of 20mm
Door Clearance	Maximum door gap = 5.5mm
Environment	Operational temperature range: -20°C to + 80°C
Lock Body	Solid Stainless Steel Construction
Lock Bolt	Solid Stainless Steel

Standards and Compliance

	CE Approved SCEC Endorsed for SL3 Medium Threat level areas
	RCM Certified
	Successfully fire rated up to 4 hours on fire door assemblies in accordance with AS1905.1.2005 (Part 1: Fire Resistant Doorsets)



PADDE SERIES

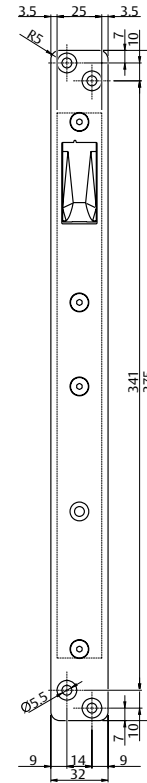
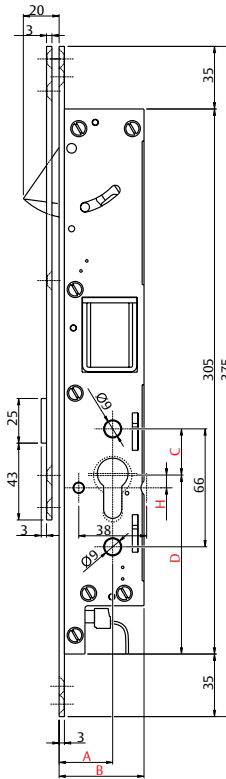
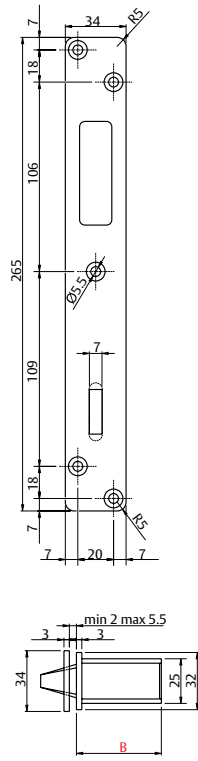

Dimensions - 30mm Backset

Dimension	Backset
A	30
B	47.5
C	25
D	101
H	8

Ordering Information

Part Number	Product Description
118203-010	ES8203 24Vdc Technilock Fail Safe 30mm
118203-011	ES8203 24Vdc Technilock Fail Safe 60mm
118204-010	ES8204 24Vdc Technilock Fail Secure 30mm
118204-011	ES8204 24Vd Technilock Fail Secure 60mm
Accessories	
228200-000	Optional Security Escutcheon for ES8200 High Security Bolt

Specification Statement

The lock must be capable of side pressure and with an overall holding force not less than 2500kgs. Also with side load pressure under pre-load conditions up to 70kg. The lock could be mounted both horizontally or vertically. It also must be monitored in the following ways; bolt locked, door closed, with an optional key-override.



ASSA ABLOY

Lockwood is the leading brand in the Australian locking industry. With an established reputation for high quality products, this iconic brand provides a wide range of locking solutions to residential housing, commercial building and industrial application markets. Lockwood is supported by an extensive distribution and after-sales support network. Our customers include retailers, architects, trade and industrial personnel, locksmiths and security dealers.

ASSA ABLOY is the global leader in door opening solutions, dedicated to satisfying end-user needs for security, safety and convenience.

ASSA ABLOY is represented in all major regions, in both mature and emerging markets, with leading positions in Australia, Europe and North America.



PADDE SERIES

The 5 Year Tricare Warranty

Our belief that we manufacture the finest premium products available in today's market place is backed by the 5 Year Tricare Warranty, ensuring that Lockwood continues to keep Australians safe by delivering security and peace of mind.

For warranty terms and conditions, please visit www.lockweb.com.au or call **1300WARRANTY**

ASSA ABLOY Australia Pty Ltd
235 Huntingdale Road
Oakleigh, Victoria, 3166
Australia

1300 LOCK UP (1300 562 587)
lockweb.com.au

Disclaimer

Whilst every effort has been made to ensure that the information (including product images and drawings) contained in this brochure is accurate at the time of publication, ASSA ABLOY Australia Pty Limited ("ASSA ABLOY") recommends that you consult ASSA ABLOY or its agents prior to placing an order to ascertain current information on specific products, as ASSA ABLOY reserves the right to make changes without notice. ASSA ABLOY will not be liable for any injury, loss or damage whatsoever, arising from any errors or omissions in the information contained in the brochure or arising from the use or application of the information contained herein. © 2021 copyright by ASSA ABLOY All rights reserved

