

## INTRODUCTION

The ceiling mount passive infrared intrusion detector is designed for the application in the residential and commercial security systems. It gives a 11 metres diameter conical protection pattern when mounted on a 3.6 metres ceiling.

It employs a low noise dual element pyro-sensor and an MCU device in security logic and environment controls.

The alternate polarity signal processor inside the MCU has very high rejection to noise due to radio interference or power surges. The MCU device also provides the functions of digital pulse counting, power-up delay and alarm output timing and controls. All of which maximizes security and false alarm immunity.

1

## FEATURES

- Low Noise Dual Element Pyro-Sensor
- Alternate Polarity Signal Processing
- Security Logics are Integrated in the MCU Device
- Surface-Mounted Component Technology, Greater EMI and RFI Immunity
- Normal or Pulse Count Response for Harsh Environments

2

## DETECTION PATTERN

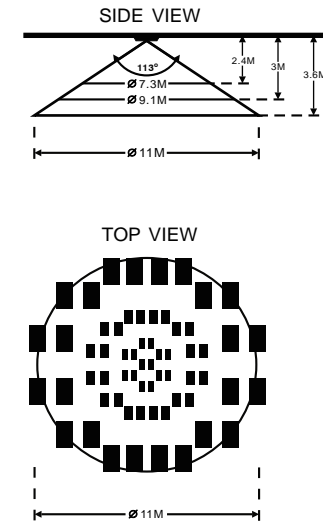

3

## P.C. BOARD & MOUNTING BASE

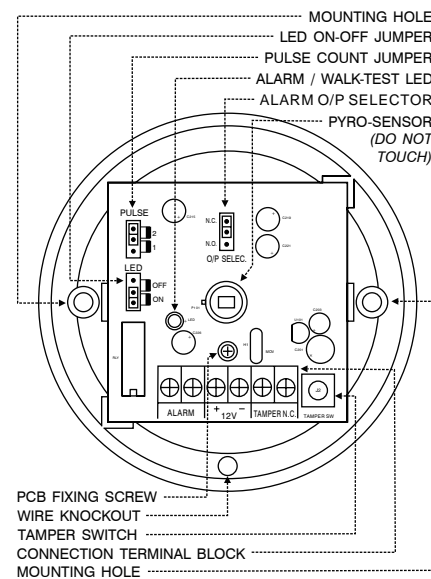

4

## CONNECTION TERMINAL BLOCK

**12V** : Connect the positive (+) side to a 8V to 16V DC power source, usually from the alarm control panel. Connect the negative (-) side to the common grounding point of the control panel.

**TAMPER:** If a tamper switch is required, connected these terminals to a 24 hour normally closed (N.C.) protection zone in the alarm control panel. The tamper switch contact is closed with the detector's front cover secured on the box. Opening of the front cover at any time will make the contact open and send an immediate alarm signal to the control panel.

**ALARM** : This is an alarm output relay contact of the detector. It is selectable for normally closed (N.C.) or normally open (N.O.) Via the alarm jumper to match the requirement of the protection of the alarm control panel.

5

## JUMPER SETTINGS

- LED** : ON ----- Enables the LED  
 "ON" for alarm condition  
 "FLASH" for power-up period  
 OFF ----- Disables the LED. Does not affect detection
- PULSE** : 1-NORMAL -- Standard Alternate Polarity Signal processing. For operation within a stable environment.  
 2-HARSH ----- Double Alternate Polarity Signal processing within 10 seconds. For a harsh environment.
- ALARM** : N.C. ----- The alarm relay output contact is normally close (N.C.). The output relay is normally energized.  
 N.O. ----- The alarm relay output contact is normally open (N.O.). The output relay is normally de-energized.

6

## INSTALLATION

### A) MOUNTING LOCATION

- \* The detector should be mounted on a stable ceiling. The maximum installation height is 12 feet (3.6m).
- \* The detector should be mounted in areas that do not have openings constantly exposed to the outside environment.
- \* Select the mounting location so that the expected motion of an intruder will cross the beam of the detection pattern.
- \* Do not locate detector where hot or cold moving air blows directly onto the unit.
- \* Avoid aiming the detector toward heating or air conditioning vents or ducts, exterior metal walls, exterior windows or curtains covering windows, refrigerator or freezer grills or other surfaces that may change temperature rapidly.
- \* Prevent putting large objects in front of the detector which will cause significant changes in the area or volume protected.

7

## SPECIFICATIONS

- \* **Current Consumption** : 15mA Typical at 12VDC
- \* **Operating Voltage** : 8-16VDC, 12VDC Nominal
- \* **Detection Method** : Passive Infrared with Alternate Polarity Signal Processing
- \* **Power-up Delay** : 2 Minutes Typical With Flashing LED Indication
- \* **Alarm Period** : 2-3 Seconds
- \* **Alarm Output** : N.C. Or N.O. Relay Contact With 10 Ohm In Line Resistor. Contact Rating: 28VDC, 0.1A
- \* **Walk Test LED** : Alarm Indicator, Enable-Disable Selectable

10

### B) MOUNTING

- \* Open the cover by gently inserting a small screw driver in the slot at the bottom of the unit, between the front cover and the base, lower the screw driver to release the cover from the base.
- \* It is necessary to remove the printed circuit board before going to mount the base in installation.
- \* Loosen the PC board fixing screw and pull out the PC board carefully.
- \* Mount the base at the location selected for optimum coverage. Use the two mounting holes at the back of the base to fasten the unit firmly to the ceiling.
- \* Use the wire knockout at the back of the base for running connection wires.

### C) WIRING AND REPLACING THE FRONT COVER

1. Put the PC board back into the base and fix it firmly with the PC board fixing screw.
2. Connect the wires to the terminal block.

8

- \* **Pulse Counting** : Normal Response Or 2 Pulses Within 10 Seconds For Harsh Environments
- \* **Tamper Switch** : N.C. Contact With 10 Ohm In Line Resistor. Contact Rating: 12VDC, 50mA
- \* **Operating Temperature**: -10°C to 55°C
- \* **Humidity** : 95% Non-Condensing
- \* **EMC** : Conforms to CE-Mark Standard
- \* **Dimensions** : 86(DIA) x 25(H) mm

*Specifications are subject to change for modification without notice.*



11

3. Put the front cover back into its position and make sure that the tamper switch is depressed when the front cover is clicked into the base.

## WALK TEST

1. Walk test can be performed after the power up delay expired (*the alarm LED is flashing during the power up period*) to test the detector over the entire protected area to verify proper operation of the unit.
2. Walk into the protected area at a rate of 1 step per second across the protection beams and observe the LED.
3. Alarm output is given when the detector is tripped under the standard alternate polarity signal processing at NORMAL condition.
4. The HARSH condition requires the detector to be tripped twice within 10 seconds to give an alarm output under the double alternate polarity signal processing operation.

9

## CEILING MOUNT PIR INTRUSION DETECTOR



## OPERATING INSTRUCTIONS

CE