



---

# Gallagher

## HBUS 16 In 16 Out Board

### Installation Note

Gallagher HBUS 16 In 16 Out Board: C300688

---

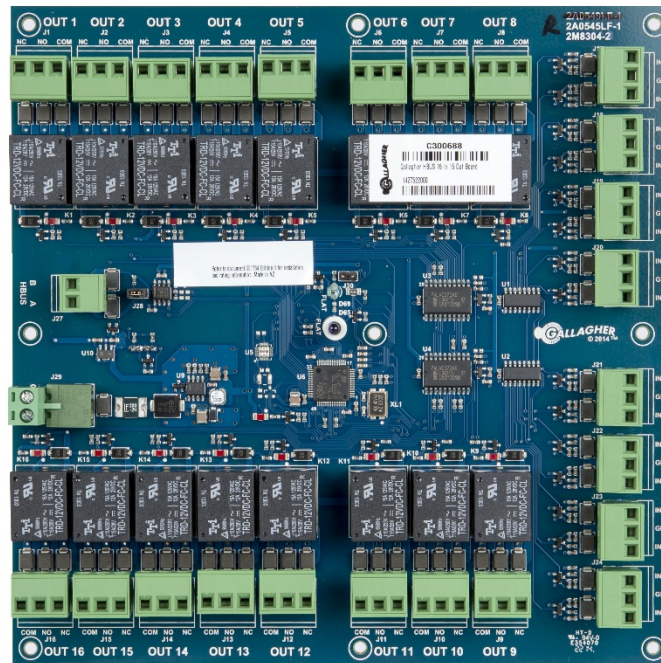

---

## **Disclaimer**

This document gives certain information about products and/or services provided by Gallagher Group Limited or its related companies (referred to as "Gallagher Group").

The information is indicative only and is subject to change without notice meaning it may be out of date at any given time. Although every commercially reasonable effort has been taken to ensure the quality and accuracy of the information, Gallagher Group makes no representation as to its accuracy or completeness and it should not be relied on as such. To the extent permitted by law, all express or implied, or other representations or warranties in relation to the information are expressly excluded.

Neither Gallagher Group nor any of its directors, employees or other representatives shall be responsible for any loss that you may incur, either directly or indirectly, arising from any use or decisions based on the information provided.

Except where stated otherwise, the information is subject to copyright owned by Gallagher Group and you may not sell it without permission. Gallagher Group is the owner of all trademarks reproduced in this information. All trademarks which are not the property of Gallagher Group, are acknowledged.

Copyright © Gallagher Group Ltd 2021. All rights reserved.

---

## Contents

---

1	Introduction .....	4
2	Before you Begin .....	4
2.1	Shipment Contents .....	4
2.2	Software .....	4
2.3	Power Supply .....	4
2.4	Building Cabling .....	5
3	Installation .....	6
3.1	Single HBUS 16 In 16 Out Board installation .....	6
3.2	Double stacking HBUS 16 In 16 Out Boards.....	6
4	Connections .....	7
4.1	Balanced Inputs .....	8
4.2	Output Relays .....	8
4.3	Tamper.....	8
5	Component Layout .....	9
6	HBUS LED Diagnostic Indications .....	9
7	Technical Specifications .....	10
8	Approvals and Compliance Standards .....	11
9	Mounting Dimensions.....	12



**ATTENTION:** This equipment contains components that can be damaged by electrostatic discharge. Ensure both you and the equipment are earthed before beginning any servicing.



**IMPORTANT:** The Gallagher HBUS 16 In 16 Out Board can only be used with Gallagher Command Centre vEL7.20 software (or later). Earlier versions of Command Centre do not support this device.

## 1 Introduction

---

The Gallagher The Gallagher HBUS 16 In 16 Out Board extends the existing connectivity of the Gallagher Controller 6000 via the HBUS communications protocol. The board provides connection for 16 inputs and 16 outputs.

The HBUS 16 In 16 Out Board is supplied as a single circuit board, designed to fit into a Gallagher Cabinet. It is designed to connect to a Controller 6000. The blue coloured PCB signifies HBUS for ease of identification. A centrally located tamper detector provides front and rear optical tamper detection.

## 2 Before you Begin

---

### 2.1 Shipment Contents

Check the shipment contains the following items:

- 1 x Gallagher HBUS 16 In 16 Out Board
- 1 x Gallagher HBUS 16 In 16 Out Board installation note (3E3473)
- 1 x Gallagher HBUS 16 In 16 Out Board component identification decal (3E3577)
- 32 x 4k7 ohm resistors

### 2.2 Software

The HBUS I/O device software is factory-loaded prior to shipment. New device software for the HBUS 16 In 16 Out Board is automatically downloaded from the Controller 6000 vGR7.20//b672 (or later).

To view the version of device software, as last reported by the board itself, click the **Connections** tab of the HBUS I/O item in Command Centre.

**Note:** The HBUS I/O item will display as offline until the item is fully configured.

### 2.3 Power Supply

Gallagher HBUS 16 In 16 Out Board requires a 13.6 Vdc  $\pm$  15% power supply. This is connected through the terminals labelled Vin and GND. An onboard 2 A resettable polyfuse provides over current protection.

The size of the DC cable supplying the HBUS I/O Devices and any other connected equipment, (e.g. readers, detectors, locks, etc.) must be of sufficient size to ensure that the voltage at the Gallagher HBUS 16 In 16 Out Board is never below 13.6 Vdc - 15% (11.56 volts).

**Note:** It is recommended that lock power be supplied via a separate cable from the control electronics, to minimise the possibility of high current spikes resulting from lock switching causing other electronic equipment to malfunction.

## 2.4 Building Cabling

The Gallagher HBUS 16 In 16 Out Board requires a minimum cable size of 4 core 24 AWG (0.2 mm<sup>2</sup>) stranded security cable. This cable allows the transmission of data (2 wires) and power (2 wires). When using a single cable to carry both power supply and data, both the power supply voltage drop and data requirements must be considered.

### HBUS Cabling Topology

The HBUS communications protocol is based on the RS485 standard and allows the board to communicate over a distance of up to 500 m (1640 ft).

The cabling between HBUS devices should be done in a "daisy chain" topology, (i.e. A "T" or "Star" topology should not be used between devices).

### Termination

The start and end devices on an HBUS circuit should be terminated using 120 ohm resistance.

If the HBUS 16 In 16 Out Board is the start or end device on an HBUS circuit, terminate the board by connecting the supplied on-board termination jumper (J28) to the board. The location of the termination jumper (J28) is shown in the topic "*Component Layout*" later in this note.

### HBUS Cabling Topology Diagrams

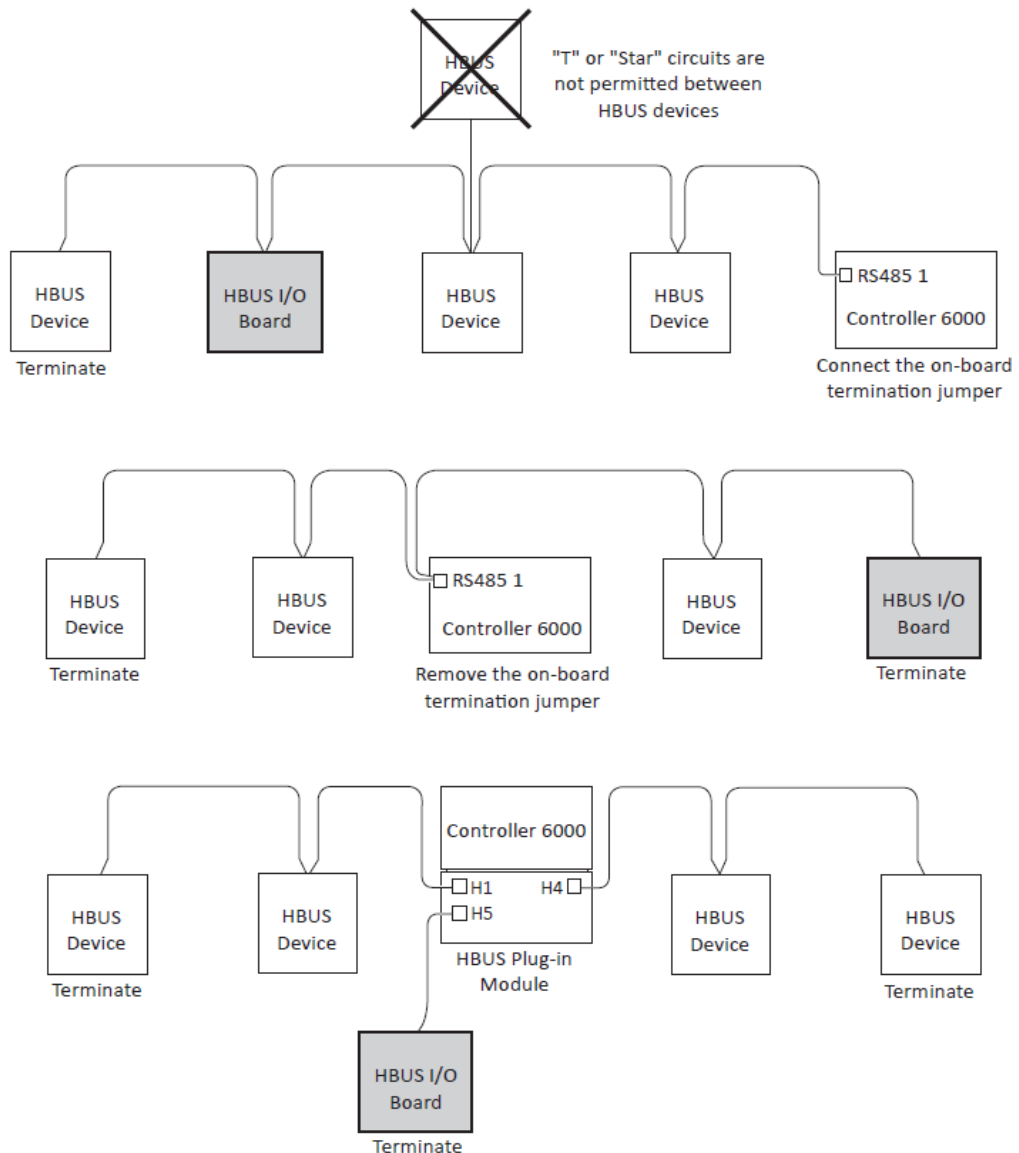

---

## 3 Installation

---

The Gallagher HBUS 16 In 16 Out Board can be mounted in a Gallagher Cabinet.

### 3.1 Single HBUS 16 In 16 Out Board installation

1. Fit the board within the cabinet, using the screws supplied with the cabinet.
2. Install all the system and power cables. Refer to the topic "*Connections*" later in this note. The cables should stow neatly and be held in place by the cable clamps fitted into the base of the cabinet.
3. Fix the component identification decal (3E3577) inside the cabinet door.  
This decal enables you to enter wiring and connection details and identifies the location and designation of cable connections, etc.  
**Note:** Do not fix the decal over the reflective label. This label is required for front optical tamper detection.
4. Configure the board in Command Centre. Refer to the topic "*Configuring an HBUS IO Interface*" in the Command Centre Configuration Client Online Help.

### 3.2 Double stacking HBUS 16 In 16 Out Boards

1. Install and wire the **bottom** board into the cabinet, using the board spacers from the Gallagher Board Spacer Kit (C200450) to screw the board into the cabinet.  
**Hint:** Fix the second half of the board's component identification decal (3E3577) inside the cabinet door. This half of the decal enables you to enter wiring and connection details for the bottom board.
2. Install and wire the **top** board into the cabinet, using the screws supplied with the cabinet.  
**Hint:** Fix the second half of the board's component identification decal (3E3577) inside the cabinet door. This half of the decal enables you to enter wiring and connection details for the top board.
3. Configure the boards in Command Centre. Refer to the topic "*Configuring an HBUS IO Interface*" in the Command Centre Configuration Client Help.  
Click the **Status and Overrides** tab and check the **Disable Front Tamper** checkbox for the bottom board.  
Click the **Status and Overrides** tab and check the **Disable Rear Tamper** checkbox for the top board.

## 4 Connections

### Notes:

- For UL installation the minimum cable size is 22 AWG.
- Run a common ground (-ve) from the Controller for all RS485 devices.

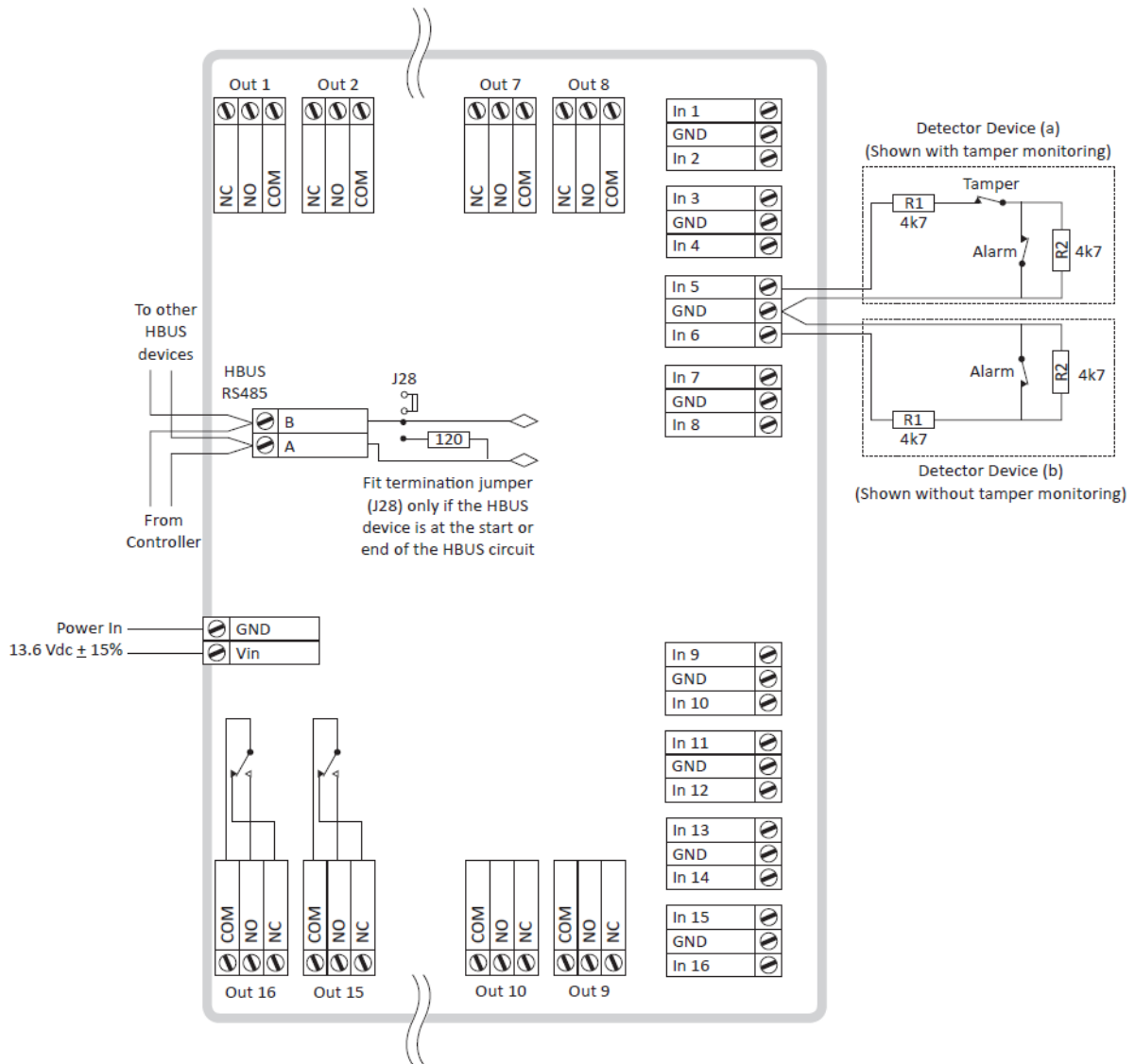

## 4.1 Balanced Inputs

Cabling should be a minimum size of 24 AWG (0.2 mm<sup>2</sup>) for all balanced inputs.

To ensure correct tamper detection (closed or open circuit), the balanced inputs require 4k7 ohm resistors to be connected as close as possible to the device being monitored.

When the monitored device incorporates a normally-closed tamper switch, it can be wired in series with resistor R1.

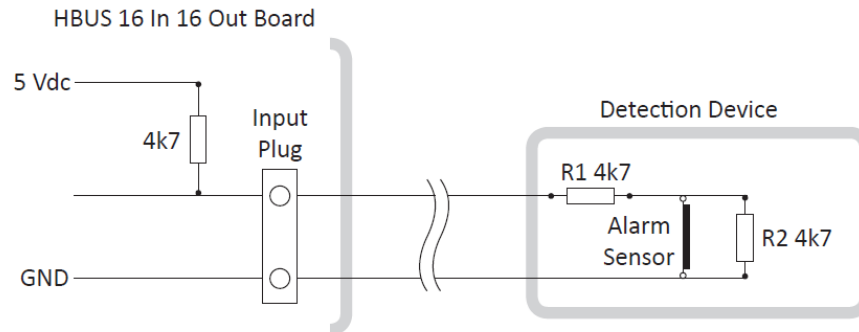

Resistor values can be configured for a HBUS 16 In 16 Out Board in Command Centre (via the EOL Resistors property page). Refer to the topic "*Configuring EOL Resistors for devices*" in the Command Centre Configuration Client Online Help.

## 4.2 Output Relays

The cabling to and from the relay connectors must be capable of carrying sufficient current for the device the relay is controlling. Each relay circuit is rated:

- 3 A at 24 Vdc/ac for a resistive load
- 1 A at 24 Vdc/ac for an inductive load

Ensure back EMF snubbing components (a diode or Metal Oxide Varistor) are fitted to inductive loads to prevent voltage spikes from causing equipment to malfunction.

## 4.3 Tamper

A centrally located tamper detector provides front and rear optical tamper detection.

**Note:** To prevent incorrect (or continuous) tamper alarms being generated by HBUS 16 In 16 Out Boards that are not being used for tamper monitoring, a Command Centre operator will need to open the properties for the HBUS I/O item in Command Centre, click the **Status and Overrides** tab and check the **Disable Front Tamper** and **Disable Rear Tamper** checkboxes.

## 5 Component Layout

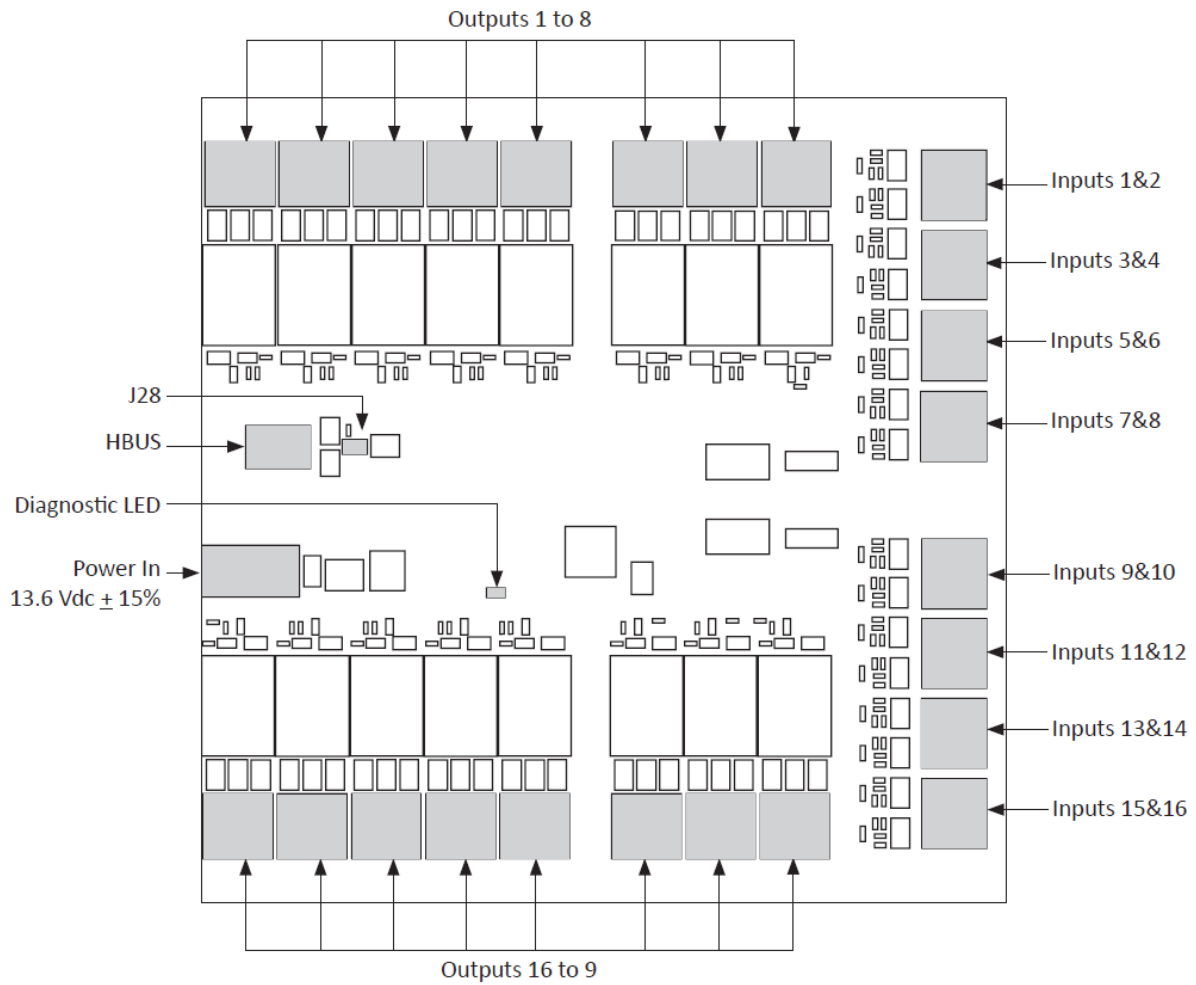

## 6 HBUS LED Diagnostic Indications

Diagnostic LED	Diagnostic Indication
3 Flash (Red)	No communications with the Controller.
2 Flash (Red)	Communications with the Controller, but module is not configured.
1 Flash (Red)	Fully configured and functioning normally.

## 7 Technical Specifications

<b>Power supply</b> Operating voltage (Vin): Fuse: Operating current:  Power rating:	13.6 Vdc $\pm$ 15% Onboard 2 A resettable polyfuse 73 mA DC (relays off) 674 mA DC (relays on)  0.99 W (relays off) 9.17 W (relays on)
<b>Environmental</b> Temperature range: Humidity:	-10 °C to +50 °C (+14 °F to +122 °F) 95% noncondensing *
<b>Connections</b> Inputs: Format:  Outputs: Format:  HBUS ports: Format:	16 4 state monitoring (configured in Command Centre)  16 24 Vdc/ac, 3 A resistive, 1 A inductive  1 RS485 balanced
<b>Shipping dimensions</b>	Height 30 mm (1.2 in) with connectors Width 180 mm (7.1 in) Depth 180 mm (7.1 in)

\* Gallagher modules are UL humidity tested and certified to 85% and have been independently verified to 95%.

## 8 Approvals and Compliance Standards



This symbol on the product or its packaging indicates that this product must not be disposed of with other waste. Instead, it is your responsibility to dispose of your waste equipment by handing it over to a designated collection point for the recycling of waste electrical and electronic equipment. The separate collection and recycling of your waste equipment at the time of disposal will help conserve natural resources and ensure that it is recycled in a manner that protects human health and the environment. For more information about where you can drop off your waste equipment for recycling, please contact your local city recycling office or the dealer from whom you purchased the product.



This product complies with the environmental regulations for the Restriction of Hazardous Substances in electrical and electronic equipment (RoHS). The RoHS directive prohibits the use of electronic equipment containing certain hazardous substances in the European Union.

### FCC

This device complies with part 15 of the FCC Rules. Operation is subject to the following two conditions: (1) This device may not cause harmful interference, and (2) this device must accept any interference received, including interference that may cause undesired operation.

**Note:** This equipment has been tested and found to comply with the limits for a Class B digital device, pursuant to part 15 of the FCC Rules. These limits are designed to provide reasonable protection against harmful interference in a residential installation. This equipment generates, uses and can radiate radio frequency energy and, if not installed and used in accordance with the instructions, may cause harmful interference to radio communications. However, there is no guarantee that interference will not occur in a particular installation. If this equipment does cause harmful interference to radio or television reception, which can be determined by turning the equipment off and on, the user is encouraged to try to correct the interference by one or more of the following measures:

- Reorient or relocate the receiving antenna.
- Increase the separation between the equipment and receiver.
- Connect the equipment into an outlet on a circuit different from that to which the receiver is connected.
- Consult the dealer or an experienced radio/TV technician for help.

**Note:** Changes or modifications not expressly approved by Gallagher Group Limited could void the user's authority to operate the equipment.

### UL Installations

Please refer to the document "3E2793 Gallagher Command Centre UL Configuration Requirements" for a guide to configuring the Gallagher system to the appropriate UL Standard. Installers must ensure these instructions are followed to ensure the installed system is UL compliant.

AS/NZS IEC 60839.11.1:2019 Grade 4, Class II

EN50130-4

EN50131-3 Grade 4, Class II

EN55032



US - Equipment: com, burg and acc module  
CA - Equipment: com, burg module



## 9 Mounting Dimensions

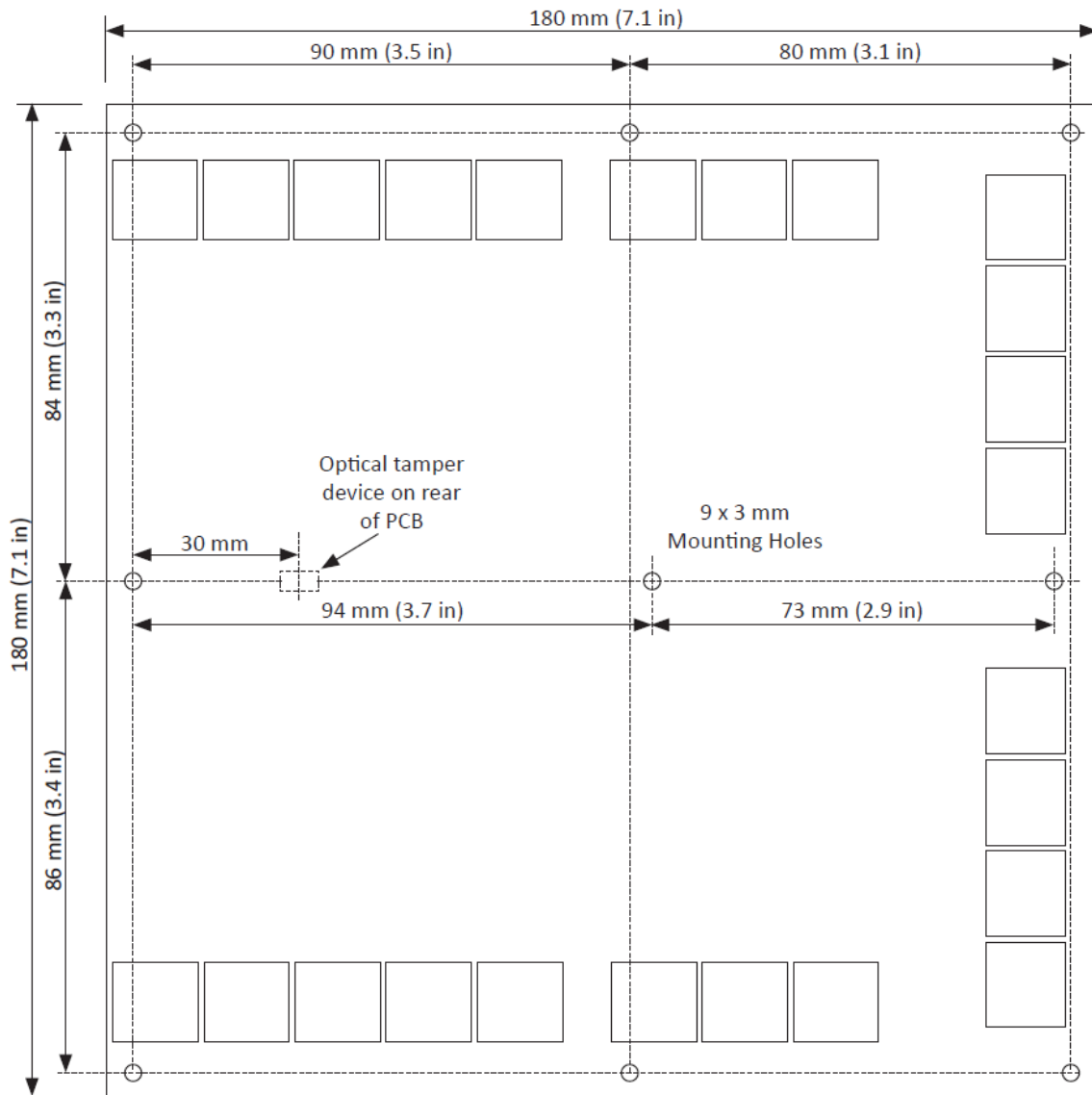

### IMPORTANT

This picture is not to scale, therefore use the measurements provided.