



CJ12-22

(12V22Ah)
(83.5w/cell)

AUS CELL No. 1

CJ12-22 is high rate series with 5 years floating design life, especially designed for high rate load discharge applications. By using strong grid and specific paste plate to insure high performance during big current discharge requirement when electricity is off., High Rate series offering extra-durable stable performance under high rate discharge.

Specification

| | |
|--|---|
| Cells Per Unit | 6 |
| Voltage Per Unit | 12 |
| Capacity | 83.5W@15min-rate to 1.67V per cell @25°C |
| Weight | Approx. 5.9Kg |
| Max. Discharge Current | 220A (5 sec) |
| Internal Resistance | Approx. 12 mΩ |
| Operating Temperature Range | Discharge: -20°C~60°C Charge: 0°C~50°C Storage: -20°C~60°C |
| Normal Operating Temperature Range | 25°C±5°C |
| Float charging Voltage | 13.7 to 13.9 VDC/unit Average at 25°C |
| Recommended Maximum Charging Current Limit | 6.0 A |
| Equalization and Cycle Service | 14.6 to 14.8 VDC/unit Average at 25°C |
| Self Discharge | Valve Regulated Lead Acid (VRLA) batteries can be stored for more than 6 months at 25°C. Self-discharge ratio less than 3% per month at 25°C. Please charge batteries before using. |
| Terminal | Faston tab F3/F13 |
| Container Material | A.B.S. (UL94-HB), Flammability resistance of UL94-V2 can be available upon request. |



MH28539



G4M20206-0910-E-16



ISO9001:2000 Certificate

Dimensions

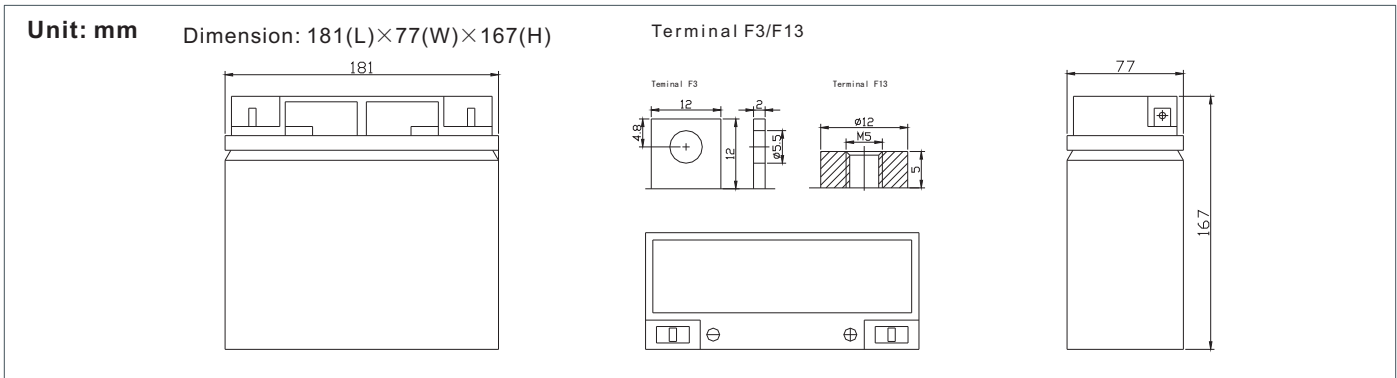

Constant Current Discharge Characteristics : A(25°C)

| F.V/Time | 5MIN | 8MIN | 10MIN | 15MIN | 20MIN | 30MIN | 60MIN | 90MIN |
|----------|-------|-------|-------|-------|-------|-------|-------|-------|
| 9.60V | 91.71 | 67.80 | 57.90 | 46.21 | 34.48 | 25.40 | 14.31 | 11.30 |
| 10.0V | 88.90 | 66.17 | 56.28 | 45.13 | 33.41 | 24.85 | 14.16 | 11.16 |
| 10.2V | 85.97 | 61.99 | 52.92 | 43.36 | 32.70 | 24.26 | 13.72 | 10.87 |
| 10.5V | 83.02 | 57.36 | 48.35 | 41.15 | 31.36 | 23.45 | 13.22 | 10.75 |
| 10.8V | 76.65 | 53.25 | 43.29 | 39.30 | 30.49 | 20.45 | 12.71 | 10.40 |
| 11.1V | 70.27 | 49.14 | 38.23 | 37.45 | 29.62 | 18.66 | 12.21 | 10.06 |

Constant Power Discharge Characteristics : W(25°C)

| F.V/Time | 5MIN | 8MIN | 10MIN | 15MIN | 20MIN | 30MIN | 60MIN | 90MIN |
|----------|-------|-------|-------|-------|-------|-------|-------|-------|
| 9.60V | 992.3 | 741.2 | 636.8 | 510.2 | 381.2 | 281.3 | 159.2 | 125.9 |
| 10.0V | 971.5 | 725.1 | 619.6 | 501.2 | 372.6 | 276.8 | 157.8 | 124.6 |
| 10.2V | 948.8 | 690.8 | 591.4 | 486.4 | 368.6 | 274.7 | 156.1 | 124.2 |
| 10.5V | 925.3 | 647.9 | 550.3 | 471.3 | 359.5 | 269.6 | 153.4 | 123.7 |
| 10.8V | 872.2 | 607.7 | 539.6 | 451.5 | 348.8 | 240.4 | 149.9 | 122.6 |
| 11.1V | 819.2 | 567.6 | 529.0 | 431.7 | 338.1 | 223.2 | 146.3 | 121.5 |

All mentioned values are average values.

Effect of temperature on long term float life

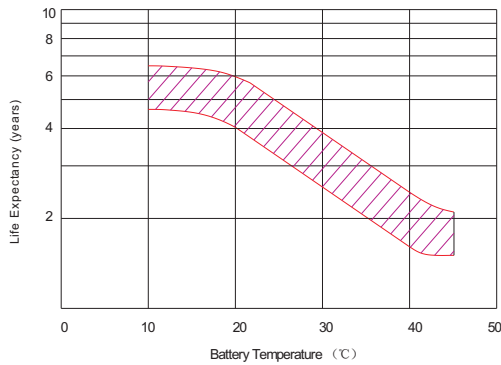

Storage characteristic

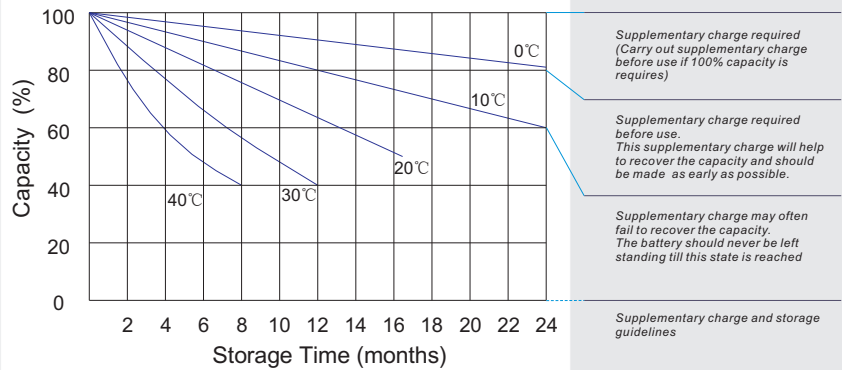

Charge characteristic Curve for standby use

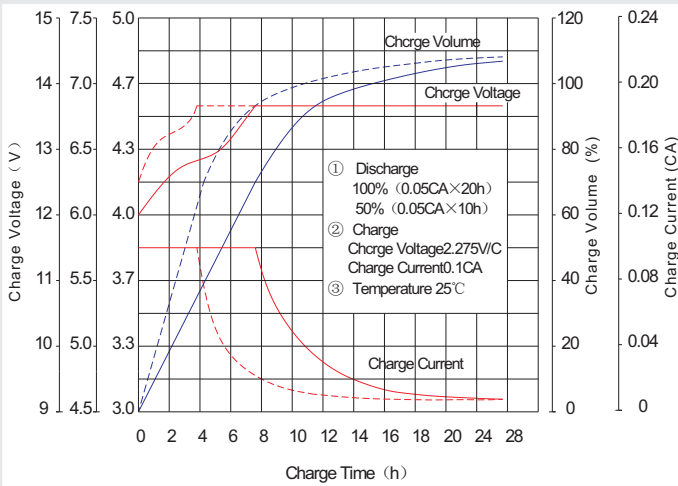

Discharge characteristic Curve

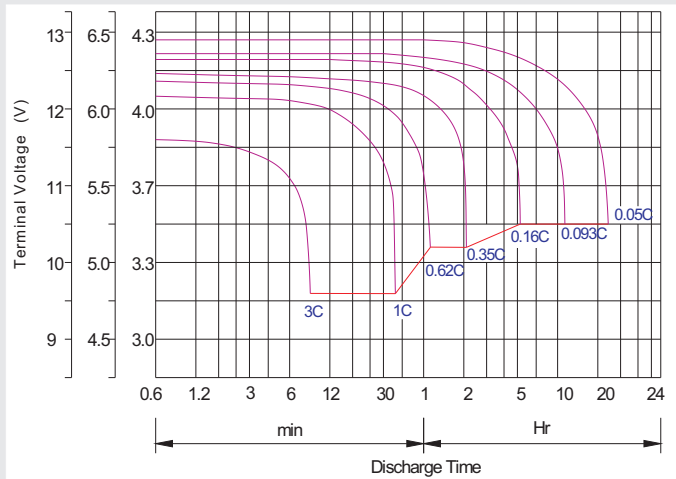

Capacity Factors With Different Temperature

| Battery Type | | -20°C | -10°C | 0°C | 5°C | 10°C | 20°C | 25°C | 30°C | 40°C | 45°C |
|--------------|--------|-------|-------|-----|-----|------|------|------|------|------|------|
| GEL Battery | 6V&12V | 50% | 70% | 83% | 85% | 90% | 98% | 100% | 102% | 104% | 105% |
| | 2V | 60% | 75% | 85% | 88% | 92% | 99% | 100% | 103% | 105% | 106% |
| AGM Battery | 6V&12V | 46% | 66% | 76% | 83% | 90% | 98% | 100% | 103% | 107% | 109% |
| | 2V | 55% | 70% | 80% | 85% | 92% | 99% | 100% | 104% | 108% | 110% |

Discharge Current VS. Discharge Voltage

| Final Discharge Voltage V/cell | 1.75V | 1.70V | 1.60V |
|--------------------------------|------------|-------------------|------------|
| Discharge Current (A) | (A) ≤ 0.2C | 0.2C < (A) < 1.0C | (A) ≥ 1.0C |

Charge the batteries at least once every six months, if they are stored at 25°C.

Charging Method:

| | |
|------------------|--|
| Constant Voltage | -0.2Cx2h + 2.4~2.5V/Cellx24h, Max. Current 0.3CA |
| Constant Current | -0.2Cx2h + 0.1CAx 12h |
| Fast | -0.2Cx2h + 0.3CAx4.0h |

Maintenance & Cautions

| |
|---|
| Float Service: |
| ※ Every month, recommend inspection every battery voltage. |
| ※ Every three months, recommend equalization charge for one time. |
| Equalization charge method: |
| Discharge: 100% rate capacity discharge. |
| Charge: Max. current 0.3CA, constant voltage 2.4-2.45V/Cell charge 24h. |
| ※ Effect of temperature on float charge voltage: -3mV/°C/Cell. |
| ※ Length of service life will be directly affected by the number of discharge cycles, depth of discharge, ambient temperature and charging voltage. |